

# FURUNO

# INSTALLATION MANUAL

MARINE RADAR

---

MODEL FR-1760DS

---



**FURUNO ELECTRIC CO., LTD.**  
NISHINOMIYA, JAPAN

© **FURUNO ELECTRIC CO., LTD.**

9-52, Ashihara-cho,  
Nishinomiya, Japan

Telephone: 0798-65-2111  
Telefax: 0798-65-4200

•Your Local Agent/Dealer

All rights reserved.

Printed in Japan

FIRST EDITION : NOV. 1998  
L : JUL. 9, 2001

(YOSH)

PUB. No. IME-34560-L  
FR-1760DS



\* 00080838000 \*



# SAFETY INSTRUCTIONS

## **WARNING**

### **Radio Frequency Radiation Hazard**

The radar scanner emits electromagnetic radio frequency (RF) energy which can be harmful, particularly to your eyes. Never look directly into the scanner aperture from a close distance while the radar is in operation or expose yourself to the transmitting scanner at a close distance.

Distances at which RF radiation levels of 100 and 10 W/m<sup>2</sup> exist are given in the table below.

**Note:** If the scanner unit is installed at a close distance in front of the wheelhouse, your administration may require halt of transmission within a certain sector of scanner revolution. This is possible. Ask your FURUNO representative or dealer to provide this feature.

Model	Radiator type	Distance to 100W/m <sup>2</sup> point	Distance to 10W/m <sup>2</sup> point
FR-1760DS	SN4A	—	1.2 m
	SN5A	—	1.0 m

## **WARNING**



**ELECTRICAL SHOCK HAZARD**

**Do not open the equipment unless totally familiar with electrical circuits and service manual.**

Only qualified personnel should work inside the equipment.



**Wear a safety belt and hard hat when working on the scanner unit.**

Serious injury or death can result if someone falls from the radar scanner mast.

**Construct a suitable service platform from which to install the scanner unit.**

Serious injury or death can result if someone falls from the radar scanner mast.

**Turn off the power at the mains switchboard before beginning the installation.**

Fire, electrical shock or serious injury can result if the power is left on or is applied while the equipment is being installed.

**Do not install the display unit where it may get wet from rain or water splash.**

Water in the display unit can result in fire, electrical shock or equipment damage.

**⚠ WARNING**

Be sure that the power supply is compatible with the voltage rating of the equipment.

Connection of an incorrect power supply can cause fire or equipment damage. The voltage rating of the equipment appears on the label above the power connector.

**Use only the specified power cable.**

Fire or equipment damage can result if a different cable is used.

**⚠ CAUTION**

 Ground the equipment to prevent electrical shock and mutual interference.

**Observe the following compass safe distances to prevent deviation of a magnetic compass:**

	Standard compass	Steering compass
Display Unit	1.15 m	0.90 m
Scanner Unit	4.8 m	3.6 m
Power supply unit PSU-002	1.2 m	0.9 m

## Danger/Warning Labels in Display Unit

This radar system contains the danger/warning labels shown below. Do not remove the labels. If a label is peeling off or is illegible, contact a FURUNO agent for replacement.

**⚠ WARNING ⚠**

To avoid electrical shock, do not remove cover. No user-serviceable parts inside.

**⚠ 警告 ⚠**

感電の恐れあり。  
サービスマン以外の方はカバーを開けないで下さい。内部には高電圧部分が多くあり、万一さわると危険です。

Name : Warning Label  
Type : 86-003-1011  
Code No. : 100-236-230

**⚠ DANGER**

Electrical shock hazard.  
Turn off power before servicing.

**⚠ 危険**

感電の恐れあり。  
サービスを行う前に、必ず電源をOFFして下さい。

Name : Danger Label  
Type : 66-022-2012  
Code No. : 100-237-730

**⚠ DANGER**

Electrical shock hazard.  
Do not touch parts inside this cover.

**⚠ 危険**

感電の恐れあり。  
カバーの内部には、絶対に触れないで下さい。

Name : Danger Label  
Type : 14-055-4202  
Code No. : 100-245-220

**⚠ DANGER**

Electrical shock hazard.  
Do not touch anode cap or its cable.

**⚠ 危険**

感電の恐れあり。  
アノードキャップ、ケーブルには絶対に触れないで下さい。

Name : Danger Label  
Type : 14-055-4201  
Code No. : 100-243-450

# TABLE OF CONTENTS

<b>EQUIPMENT LISTS</b> .....	iv
<b>SYSTEM CONFIGURATION</b> .....	vi

## **MOUNTING**

1.1 Scanner Unit .....	1-1
1.2 Display Unit .....	1-7
1.3 Power Supply Unit.....	1-8

## **WIRING**

2.1 Scanner Unit .....	2-1
2.2 Display Unit .....	2-5
2.3 Power Supply Unit.....	2-8
2.4 Installation and Connection of Rectifier Unit .....	2-9

## **EXTERNAL SIGNAL INPUT, OUTPUT**

3.1 Input From External Equipment .....	3-1
3.2 Output to External Equipment .....	3-2
3.3 Connection of External Buzzer .....	3-3
3.4 Data Sentences .....	3-4

## **INITIALIZATION AND ADJUSTMENT**

4.1 Tuning .....	4-1
4.2 Accessing Menus for Initialization and Adjustment .....	4-2
4.3 Heading Alignment .....	4-3
4.4 Adjusting Sweep Timing .....	4-4
4.5 Adjusting Video Signal Level .....	4-5
4.6 Suppressing Main Bang .....	4-6
4.7 Confirming Magnetron Heater Voltage .....	4-6
4.8 Initial Settings .....	4-8
4.9 Changing Input Voltage .....	4-10

## **OPTIONAL EQUIPMENT**

5.1 Gyro Converter GC-8 .....	5-1
5.2 Automatic Tracking Aid ARP-17 .....	5-8
5.3 Video Plotter RP-17 .....	5-13

<b>PACKING LISTS</b> .....	A-1
----------------------------	-----

<b>OUTLINE DRAWINGS</b> .....	D-1
-------------------------------	-----

<b>INTERCONNECTION DIAGRAM</b> .....	S-1
--------------------------------------	-----

<b>SCHEMATIC DIAGRAMS</b> .....	S-2
---------------------------------	-----

# EQUIPMENT LISTS

## Standard Supply

Name	Type	Code No.	Qty	Remarks
Scanner Unit	SN4A-RSB-0051-N	–	Select one	2500 mm, w/o de-icer
	SN4A-RSB-0051-I	–		2500 mm, w/de-icer
	SN5A-RSB-0051-N	–		2700 mm, w/o de-icer
	SN5A-RSB-0051-I	–		2700 mm, w/de-icer
Display Unit	RDP-120	–	1	
Power Supply Unit for Scanner Unit	PSU-002-60	–	Select one	100 VAC
	PSU-002-61	–		110 VAC
	PSU-002-62	–		115 VAC
Spare Parts	SP03-12700	000-086-940	1	SP03-12701: Display Unit SP03-09202: Power Supply Unit SP03-09203: Scanner Unit
Installation Materials	CP03-19460	000-086-941	Select one	CP03-19404: Display Unit CP03-11603: Scanner Unit CP03-11602: Power Supply Unit Signal Cable S03-78-15 (15 m)
	CP03-19470	000-086-942		CP03-19404: Display Unit CP03-11603: Scanner Unit CP03-11602: Power Supply Unit Signal Cable S03-78-20 (20 m)
	CP03-19480	000-086-943		CP03-19404: Display Unit CP03-11603: Scanner Unit CP03-11602: Power Supply Unit Signal Cable S03-78-30 (30 m)
	CP03-19490	000-086-944		CP03-19404: Display Unit CP03-11603: Scanner Unit CP03-11602: Power Supply Unit Signal Cable S03-78-60 (60 m)
Accessories	FP03-06520	000-086-945	1	FP03-06521 (Hood), FP03-06522

S  
E  
E  
  
P  
A  
C  
K  
I  
N  
G  
  
L  
I  
S  
T  
S

## Optional Equipment

Name	Type	Code No.	Qty	Remarks
Rectifier	RU-3424	000-030-497	1	Display Unit, 220 VAC
	RU-1758	000-030-416	1	Power Supply Unit, 220 VAC
	RU-1803	000-030-420	1	Power Supply Unit, 440 VAC
	RU-3305	000-030-448	1	De-icer
Remote Display	FMD-8010	–	1	
Gyro Converter	GC-8-B-2	008-500-930	1	Separate shipment
Automatic Tracking Aid	ARP-17	008-488-840	1	
Dust Cover	03-143-1711	100-265-930	1	
Filter	OP03-152	–	1	
Power Cable	CVV-S8x2c	000-560-634	1	15 m
External Buzzer	OP03-21	000-030-097	1	
Handle	OP03-70	008-423-420	1	
Remote Display	FMD-811	–	1	
AD Converter	AD-100	–	1	
Signal Cable	S03-55-5(5P)	008-455-160	1	
Cable	660V-MPYCY-16 10 m	000-125-725	1	
Cable	660V-MPYCY-16 20 m	000-125-726	1	
Cable	660V-MPYCY-16 30 m	000-125-727	1	
Cable	660V-MPYCY-16 50 m	000-125-728	1	
Video Plotter	RP-17-17E-2	000-086-989	1	
RAM Card	OP03-115	008-451-170		256 KB, for RP-17
RAM Card	OP03-116	008-451-180		512 KB, for RP-17

# SYSTEM CONFIGURATION

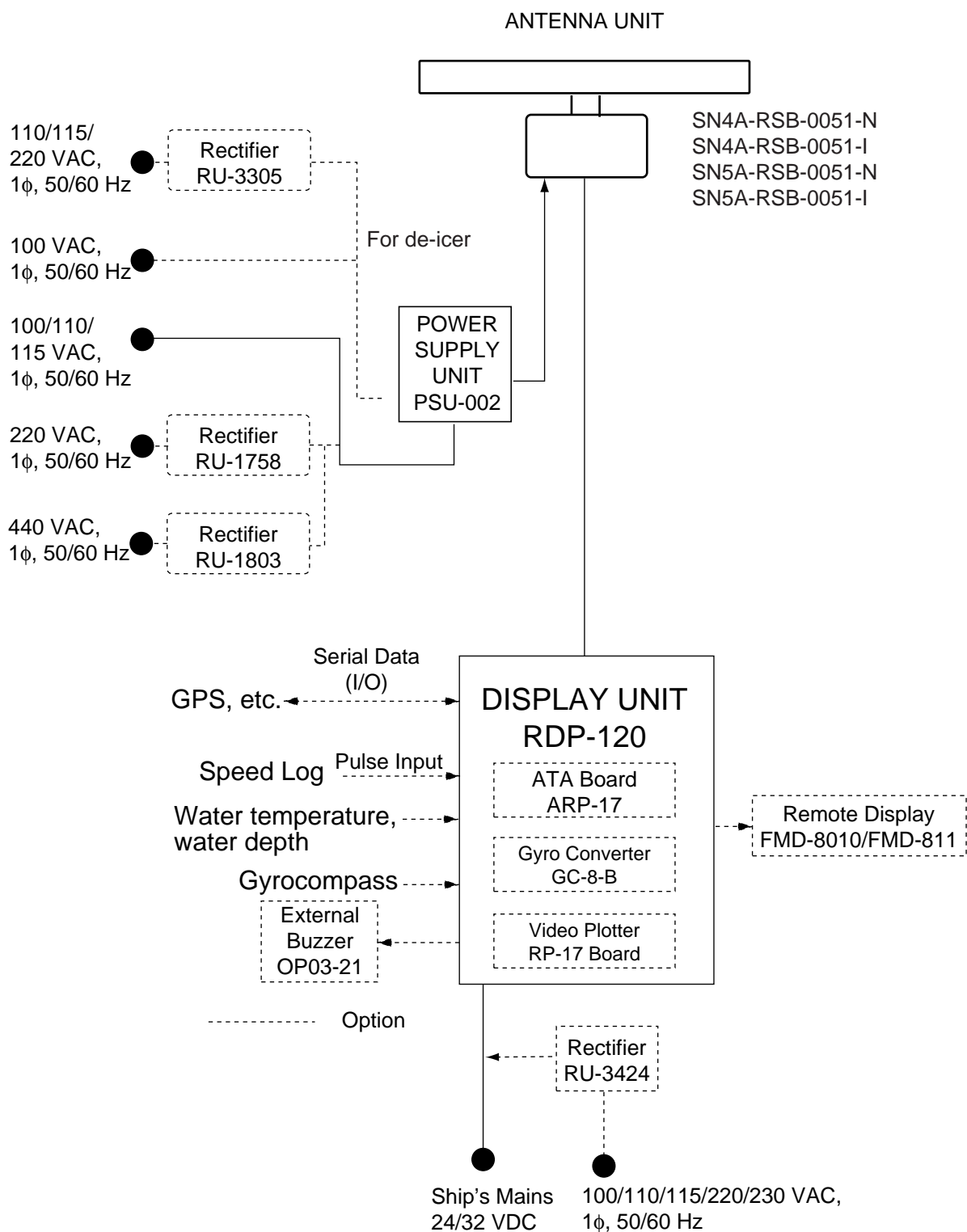



## 1.1 Scanner Unit

### Mounting considerations

- The scanner unit is generally installed either on top of the wheelhouse or on the radar mast, on a suitable platform. Locate the scanner unit where there is a good all-round view.
- No funnel, mast or derrick should be within the vertical beamwidth of the scanner in the bow direction, especially zero degrees  $\pm 5^\circ$ , to prevent blind sectors and false echoes on the radar picture.
- It is rarely possible to place the scanner unit where a completely clear view in all directions is available. Thus, you should determine the angular width and relative bearing of any shadow sectors for their influence on the radar at the first opportunity after fitting.
- Locate the antenna of a direction finder clear of the scanner unit to prevent interference to the direction finder. A separation of more than two meters is recommended.
- To lessen the chance of picking up electrical interference, avoid where possible routing the signal cable near other onboard electrical equipment. Also avoid running the cable in parallel with power cables.
- A magnetic compass will be affected if placed too close to the scanner unit. Observe the following compass safe distances to prevent deviation of a magnetic compass: Standard compass, 4.8 m, Steering compass, 3.6 m.
- Do not paint the radiator aperture, to ensure proper emission of the radar waves.
- The signal cable run between the scanner and the display is available in lengths of 15 m (standard), 20 m, 30 m and 60 m. Whatever length is used it must be unbroken; namely, no splicing allowed.
- Deposits and fumes from a funnel or other exhaust vent can adversely affect the aerial performance and hot gases may distort the radiator portion. The scanner unit must not be mounted where the temperature is more than 70°C.
- The scanner base is made of cast aluminum. To prevent electrolytic corrosion of the scanner base, use the seal washers and corrosion-proof rubber mat and ground the unit with the ground wire (supplied).
- Leave sufficient space around the unit for maintenance and servicing. See the scanner unit outline drawing for recommended maintenance space.

## Installation precaution for S-band scanner unit

If an S-band scanner unit is mounted near the end of a platform to provide sufficient rotation clearance for the radiator, the scanner unit, because of its weight, swings up and down by ship's vibration and rolling, exerting excessive levels of stress at the base of the radiator, which can damage the radiator. To prevent this, relocate the scanner unit, or if relocation is not possible, reinforce the platform.

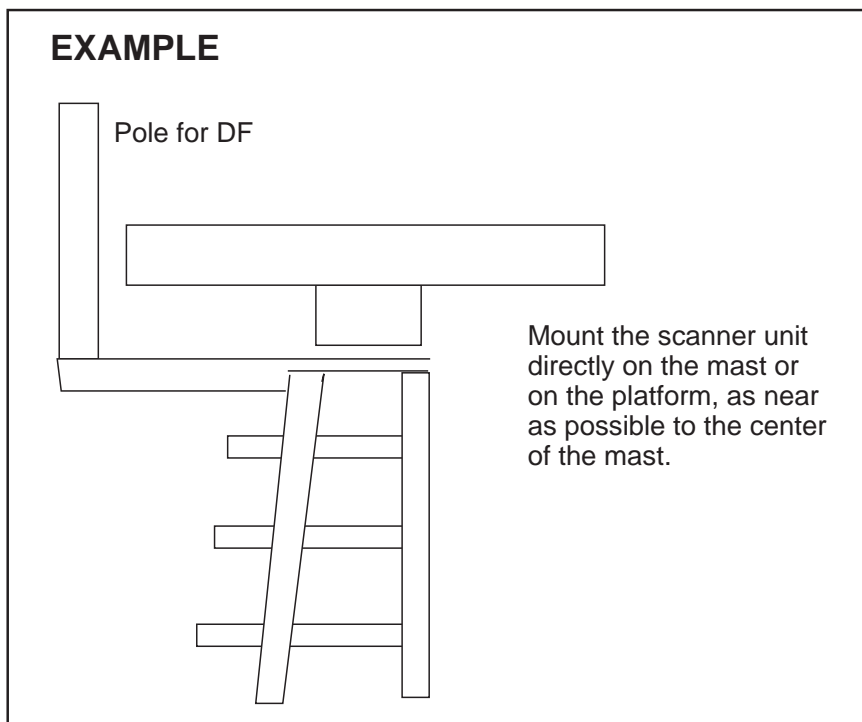
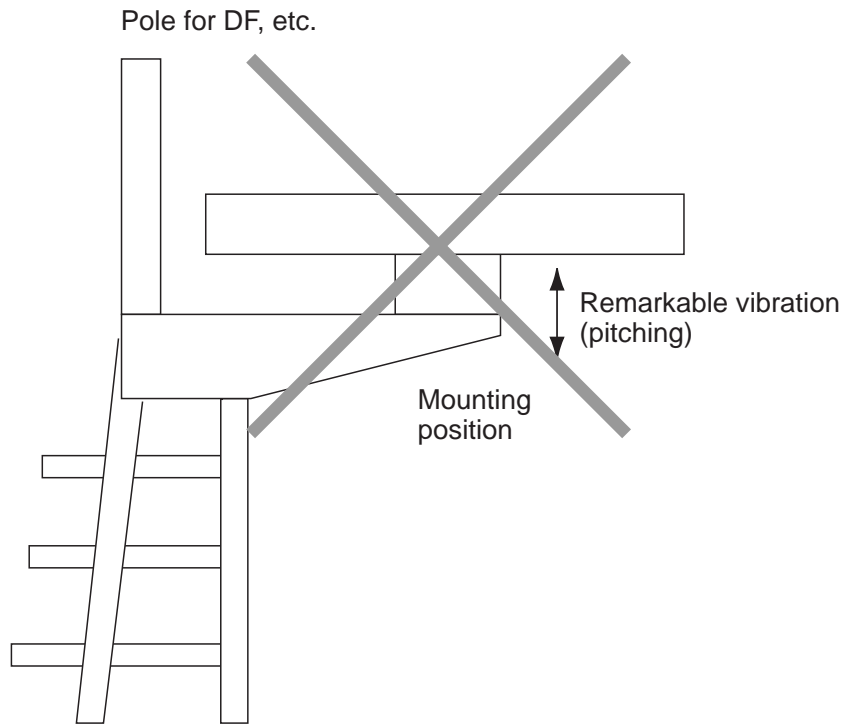

Figure 1-1 Mounting of S-band scanner unit

## Scanner unit assembling

The scanner radiator and the scanner housing are shipped in separate packages and must be assembled at installation. Assemble them as below.

The scanner unit may be assembled before hoisting it to the mounting platform. However, do not lift the scanner unit by the radiator.

1. Remove two protective caps from the radiator flange and rotary joint flange.
2. Grease an O-ring and place it in the groove of the rotary joint flange. Make sure the O-ring is not pinched during assembling.
3. Secure the feeder waveguide to the rotary joint flange with four M6x16 hex bolts.
4. Fix the feeder waveguide on the radiator bracket with a waveguide clamp, a clamp insulator, two flat washers, and two M6x50 hex bolts.
5. Grease other O-ring and set it in the groove of the radiator flange.
6. Set the scanner radiator to the bracket and fix it temporarily with eight M10x20 hex bolts, spring washers and flat washers.
7. Fasten the feeder waveguide to the radiator flange with four M6x16 hex bolts.
8. Fasten the scanner radiator to the bracket with eight M10x20 bolts.

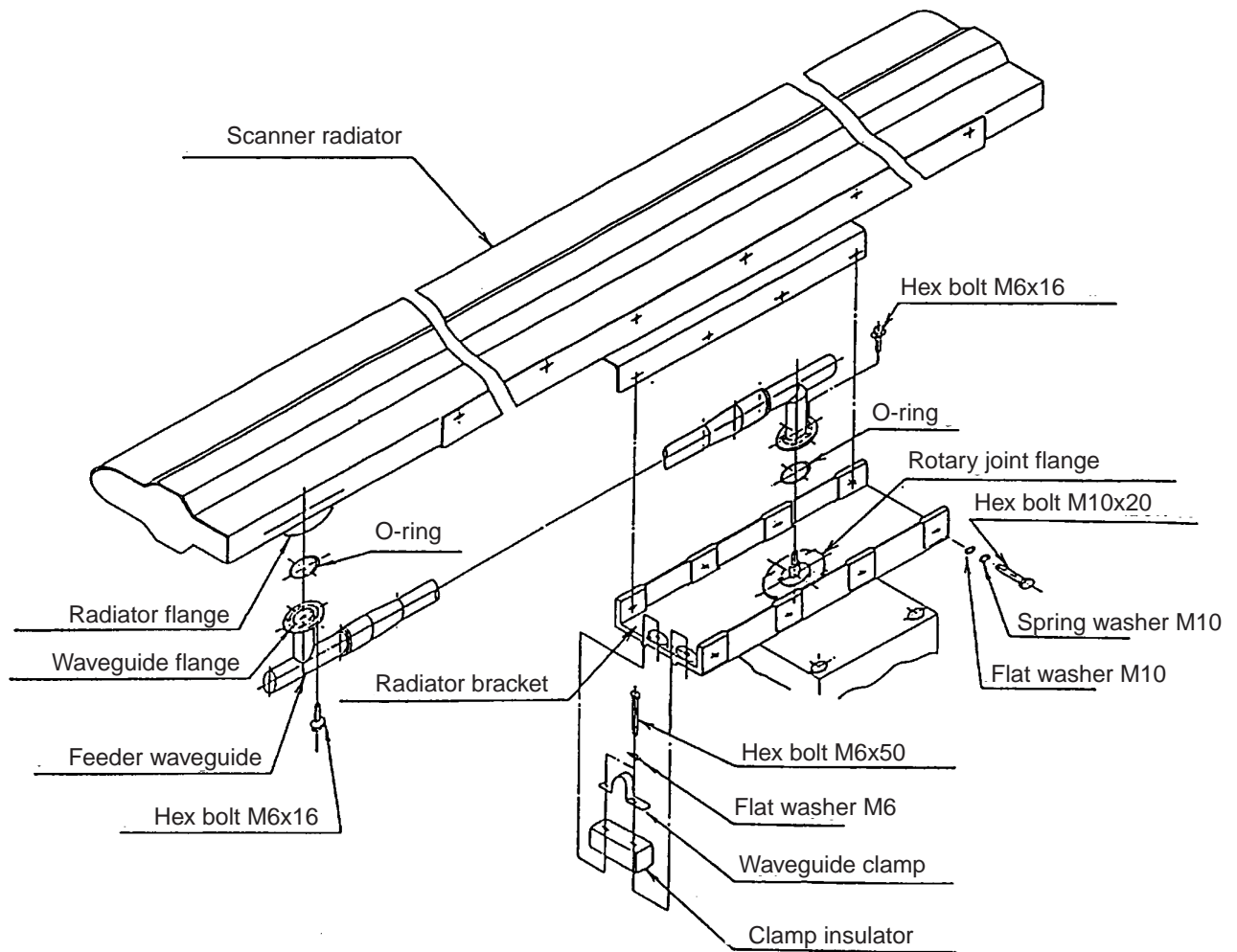

Note 1: Coat bolts, nuts, washers and waveguide flanges outside O-ring grooves to prevent electrolytic corrosion. (Do not allow silicone sealant to touch O-ring and O-ring grooves.)

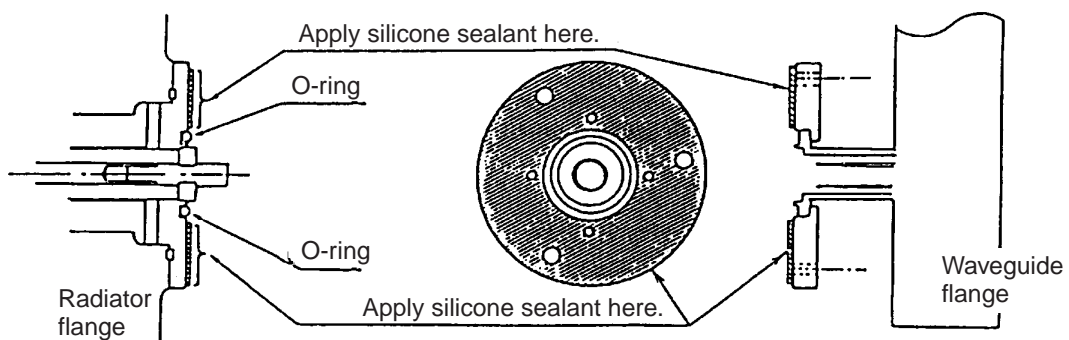

Note 2: Do not pinch O-ring and keep it clean.

Note 3: Use grease on scanner covers and O-rings. Do not use silicone sealant.

Figure 1-2 Scanner unit assembling

## Mounting the scanner unit

1. Referring to the scanner outline drawing, drill four bolt holes (15 mm dia.) in the radar mast platform or the deck.
2. Place the corrosion-proof rubber mat (supplied) on the mounting platform.
3. Using the two L-angle metal plates on the scanner top, lift the scanner base with the antenna radiator and place the scanner unit on the rubber mat. Orient the scanner so its cable glands face the ship's stern.

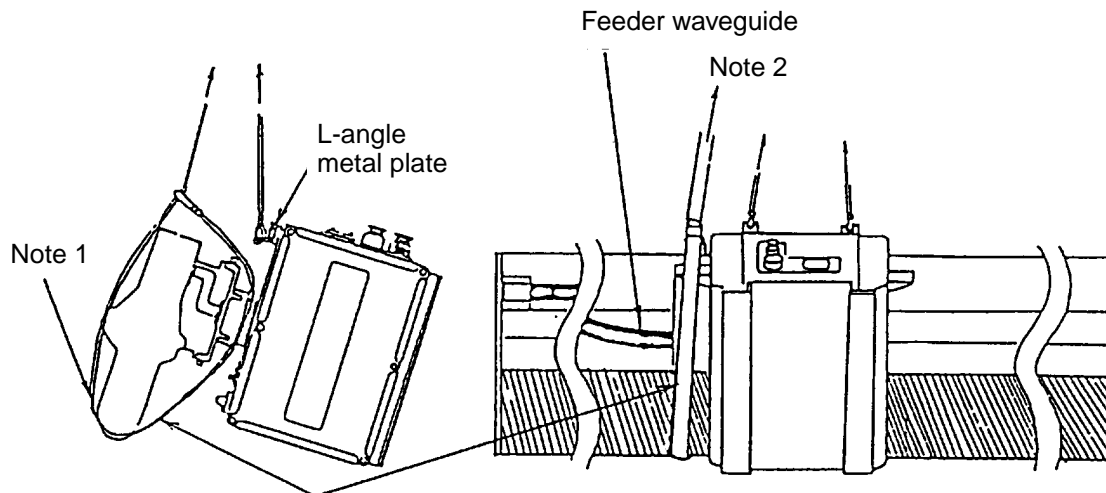

Place the rope around scanner radiator (feeder waveguide side) to prevent scanner from rotating when lifting the scanner base.

Note 1: Take care not to damage scanner exterior by the rope.

Note 2: Tensile load should not be applied to scanner radiator.

*Figure 1-3 How to lift the scanner unit*

4. Fix the scanner base to the mounting platform with four M12x60 hex bolts, nuts, washers and seal washers (supplied).
5. Arrange the grounding terminal at the nearest grounding spot with the M6x25 hex bolt, nut and washers (supplied). Then, fix a ground wire (RW-4747, 340 mm) to the terminal.
6. Connect the other end of the ground wire to the ground terminal of the scanner unit.
7. Coat grounding terminal and fixing bolts on the scanner unit with silicone sealant (supplied).

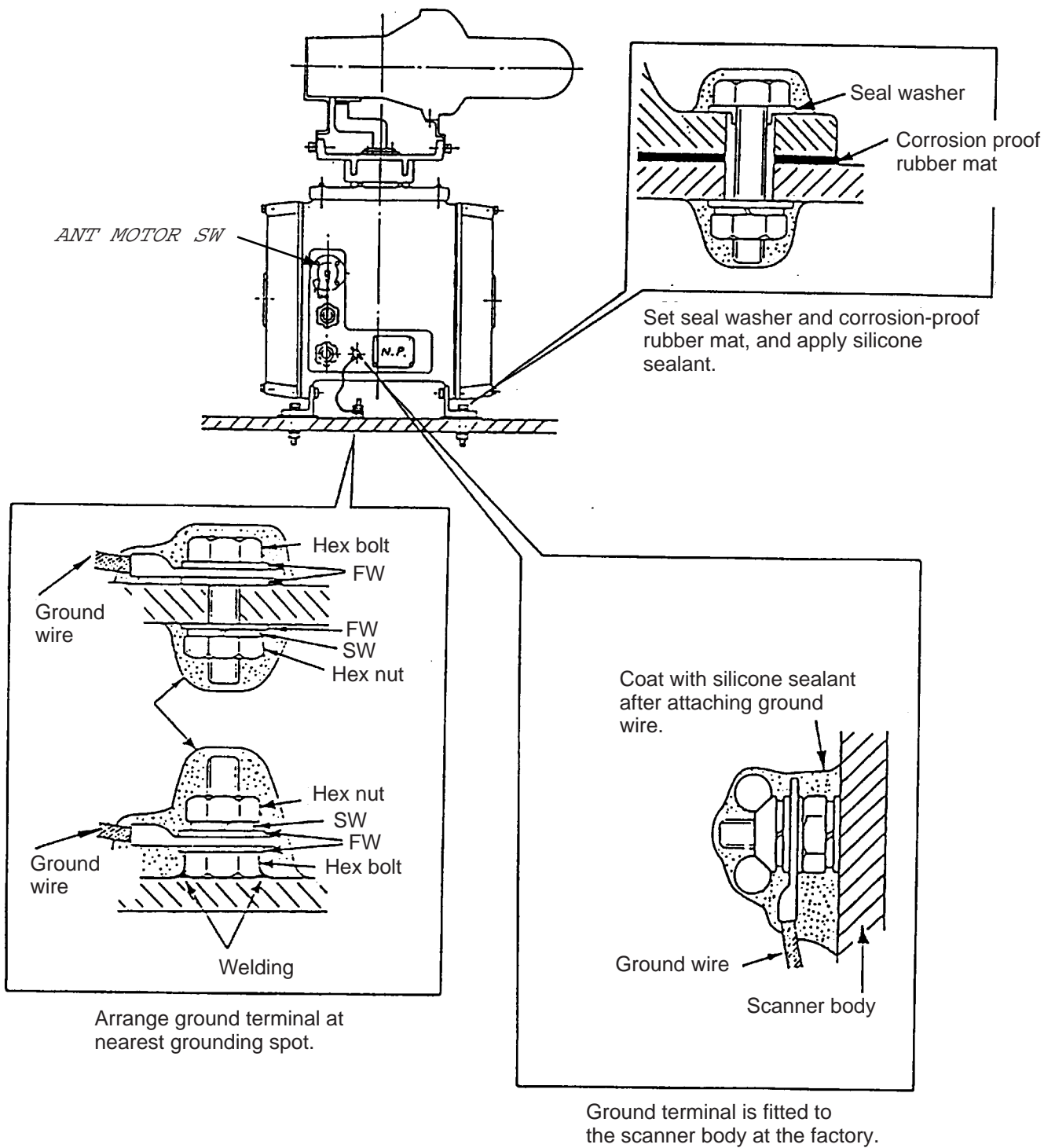

Figure 1-4 Mounting of scanner unit

## 1.2 Display Unit

### Mounting considerations

When selecting a mounting location, keep in mind the following points:

- Select a location where the display unit can be viewed and operated conveniently and where the screen can be viewed while facing towards the bow.
- Locate the unit out of direct sunlight and away from heat sources because of heat that can build up inside the cabinet.
- Locate the equipment away from places subject to water splash and rain.
- Be sure the mounting location is strong enough to support the weight of the unit under the continued vibration which is normally experienced on the ship. If necessary reinforce the mounting location.
- Determine the mounting location considering the length of the signal cable between the scanner unit and the display unit. (The signal cable comes in lengths of 15, 20, 30 or 60 meters; maximum 100 meters).
- Leave sufficient space on the sides and rear of the unit to facilitate maintenance. Also, leave a foot or so of "service loop" in cables behind the unit so it can be pulled forward for servicing or easy removal of connectors.
- A magnetic compass will be affected if placed too close to the display unit. Observe the following compass safe distances to prevent deviation of a magnetic compass: Standard compass, 1.15 m, Steering compass, 0.90 m.

### Mounting procedure

1. Loosen the two screws at the front of the display unit.

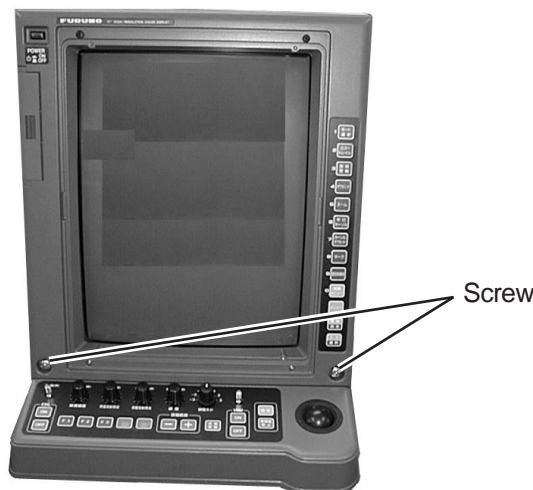

*Figure 1-5 Display unit, front view*

2. Lift the front panel.



*Figure 1-6 Display unit, cover opened*

3. Unfasten two bolts (M8 x 40) at the bottom front of the display unit, and then remove the mounting base.
4. Mark screw locations in the tabletop, using the mounting base as a template. For mounting by bolts, nuts and washers, drill four holes of 12 mm diameter in the tabletop.
5. Fasten the mounting base to the tabletop by tapping screws, or M10, bolts, nuts and washers.
6. Lay the display unit on the mounting base. Fasten the display unit to the mounting base with the two M8 x 40 bolts removed at step 3.
7. Close the cover and fasten it.

#### Optional handles

Handles are available. Detach the caps attached to the display unit and fasten the handles.

## 1.3 Power Supply Unit

The Power Supply Unit PSU-002 does not contain usual operating controls. Therefore, they can be installed in any recessed place either in vertical or horizontal position. However, select a dry and well-ventilated location and observe the compass safe distances below to prevent deviation of a magnetic compass.

	<b>Standard Compass</b>	<b>Steering Compass</b>
Compass safe distance	1.2 m	0.9 m



## 2.1 Scanner Unit

Two signal cables are terminated at the scanner unit: signal cables S03-78 and 660V-MPYCY-16 (from the power supply unit).

### Preparations

Open the port side cover (six bolts) of the scanner unit. Unfasten fixing plates to access terminal boards.

### Signal cable S03-78 (JIS cable)

1. Shorten the cable, extending the length actually required by 600 mm. Strip off about 600 mm of the anti-corrosive vinyl sheath and 590 mm of the armor and the inner vinyl sheath, being careful not to nick the braided shield.

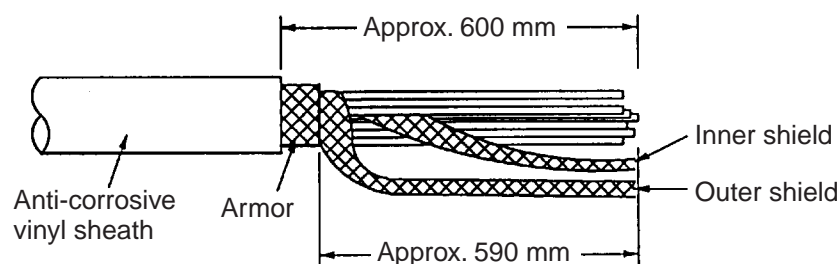

Figure 2-1 Fabricating the signal cable S03-78

2. Turn off the ANT MOTOR SW on the scanner unit(Refer to figure 1-4).
3. Unravel the outer shield with a screwdriver or similar tool to expose the cores beneath the outer shield.
4. Similar to step 2, expose the cores beneath the inner shield. Mark all cores for future identification.
5. Slide the clamping gland, washers and gasket onto the cable. (Use lower side gland.)

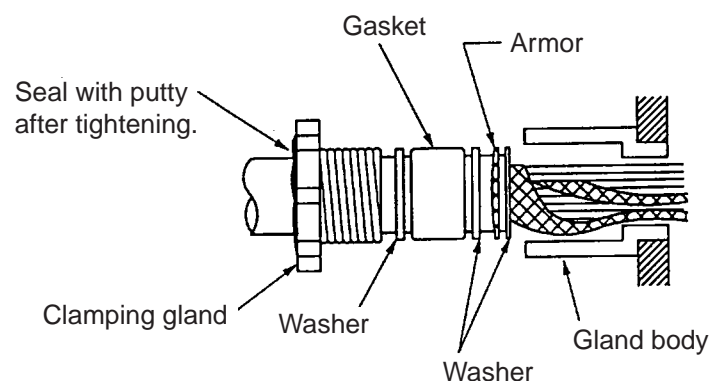
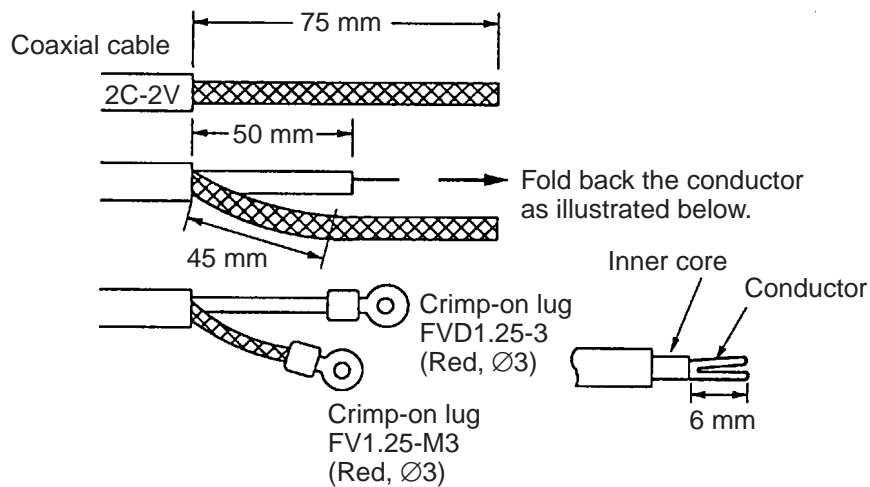

Figure 2-2 Passing clamping gland, washers and gasket on signal cable

6. Ground the armor through the two washers as shown above. Trim the shields considering their location on the earth terminal inside the scanner unit. Fit a crimp-on lug (yellow, FV5.5-4,  $\varnothing 4$ ) to inner and outer shields, then connect them to the ground terminal inside the scanner unit.
7. Determine the length of each core considering its location on STB-1 in the scanner unit (see the interconnection diagram on page S-1). Remove approx. 6 mm of the vinyl insulation from the end of each core and fix the crimp-on lug FV1.25-M3 (Red) to each core.
8. Remove the outer sheath of the coaxial cable (2C-2V) by 75 mm. Pull back the braided shield to expose the inner core. Remove approx. 25 mm of insulator from the end of inner core and fold back conductor as illustrated below. Shorten the shield leaving approx. 45 mm. Fit crimp-on lugs to the conductor (FVD1.25-3, Red) and braided shield (FV1.25-M3, Red).



*Figure 2-3 Fabrication of coaxial cable*

9. Lead cable into cable gland, tighten clamping gland and seal with putty.
10. Connect wiring to terminal STB-1 in the scanner unit referring to the interconnection diagram.

## Signal cable 660V-MPYCY-16 (JIS cable)

1. Unfasten the clamping gland from the upper cable gland, and remove the gasket and flat washers.
2. Shorten the cable as appropriate. Remove the vinyl sheath by 600 mm. Remove the armor by 590 mm.

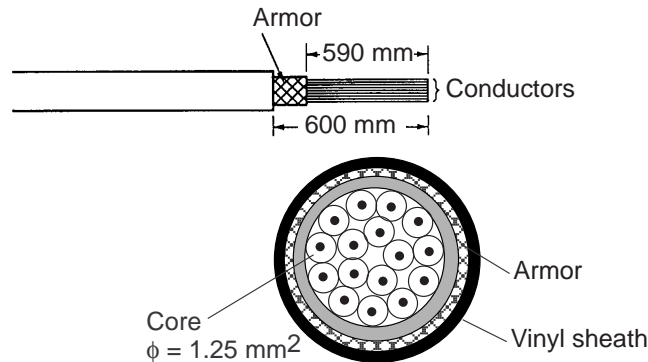

Figure 2-4 Fabrication of signal cable 660V-MPYCY-16

3. Slide the clamping gland, washers and gasket on the power cable. Fold back the armor by 5 mm, then put it between washer and cable gland body as below.

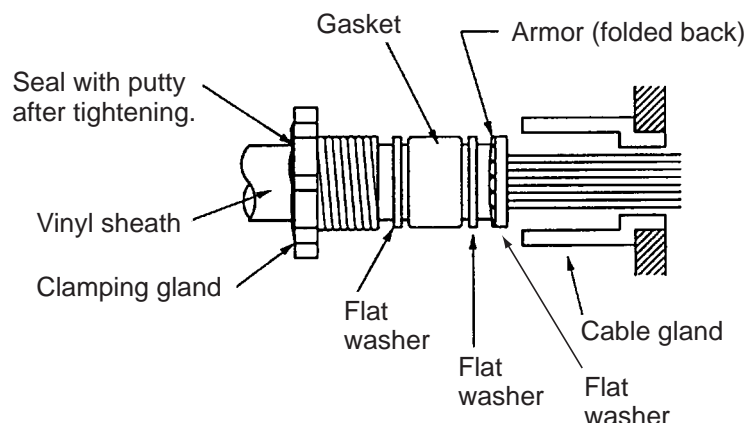
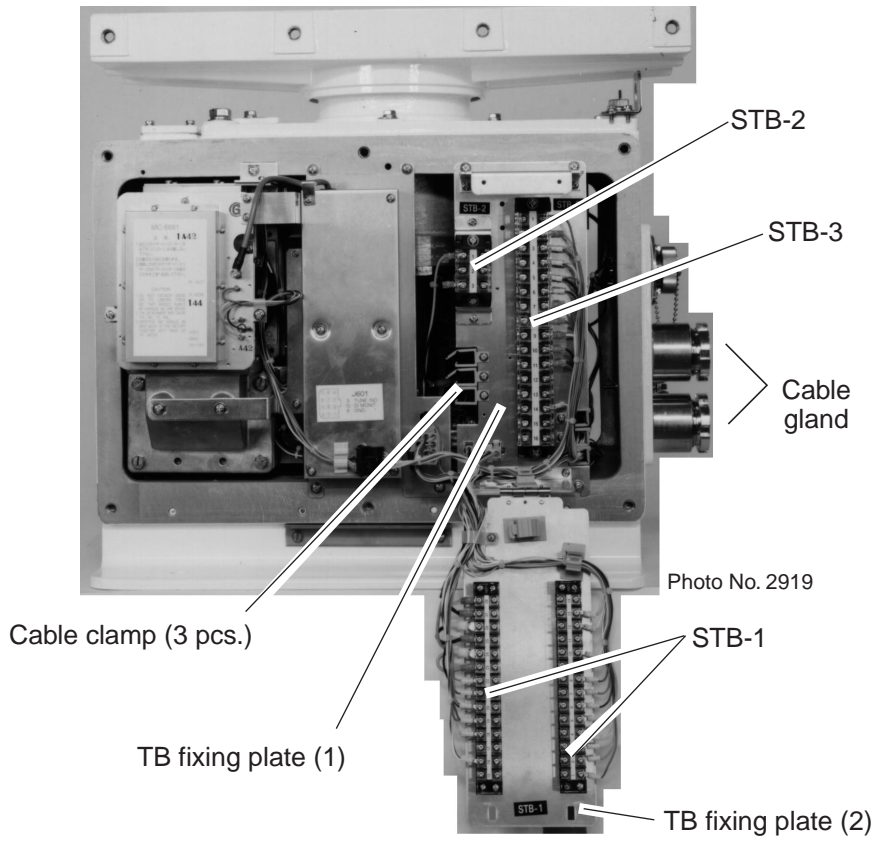
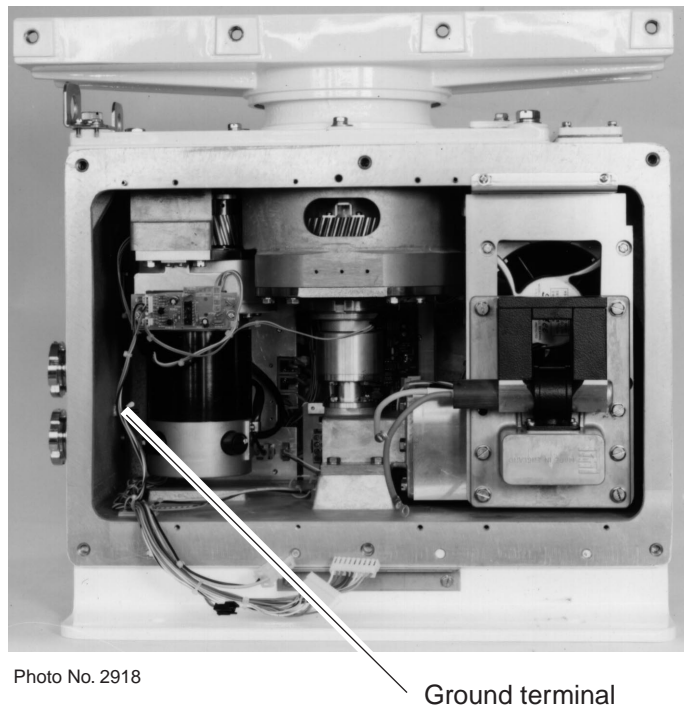

Figure 2-5 Passing clamping gland, washers and gasket on the signal cable

4. Determine the length of the cores considering their location on STB-2 and STB-3. Trim conductors as appropriate.
5. Ground the armor by inserting it through the two flat washers near the cable gland.
6. Remove the sheath of each core by 6 mm. Fix crimp-on lug FV1.25-4 (Blue,  $\varnothing 4$ ) to each conductor. Make sure each connection is secure both electrically and mechanically.
7. Lead cable into cable gland, tighten clamping gland and seal with putty.
8. Connect the conductors to STB-2 and STB-3, referring to the interconnection diagram on page S-1.
9. Check for loose screws and poor contact on crimp-on lugs. Close terminal boards.
10. Grease the fixing bolts for the cover, gasket and tap holes in the scanner chassis. Attach cover.



*Figure 2-6 Scanner unit, port side view*



*Figure 2-7 Scanner unit, starboard side view, Rf chassis removed*

## 2.2 Display Unit

### Switch S2

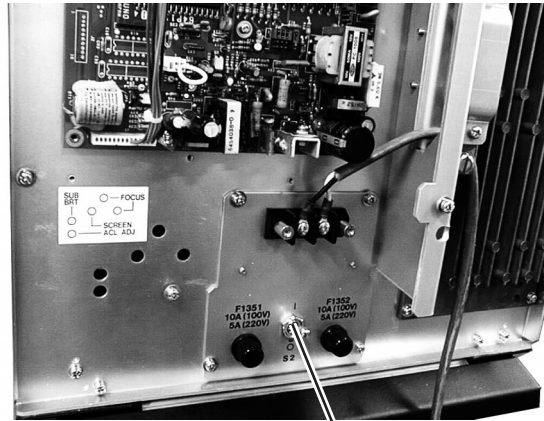

Switch S2 (AC spec. only)

The display unit designed to run on AC power has a switch (S2) at its rear to cut off 100/200 VAC power to the display unit. To access the switch, unscrew two screws and then slide cover to remove it. **TURN THE SWITCH OFF WHENEVER ACCESSING INSIDE THE DISPLAY UNIT.**

### Fabricating the power cable CVV-S 8X2C (option)

1. Remove the vinyl sheath by 40 mm.
2. Cut off jute tape wrapped around the armor.
3. Unravel the armor to expose the cores.
4. Remove insulation of cores by about 10 mm. Fix crimp-on lugs to the cores and armor.
5. Cover the armor with vinyl tape, leaving the portion which will lie inside the cable clamp untaped.

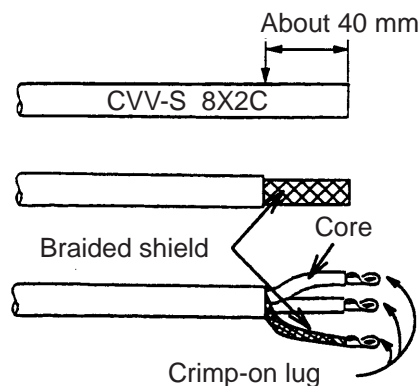

Figure 2-8 Fabrication of power cable CVV-S 8X2C

## Wiring

All wiring of the display unit is done on the SPU Board at the rear of the display unit.

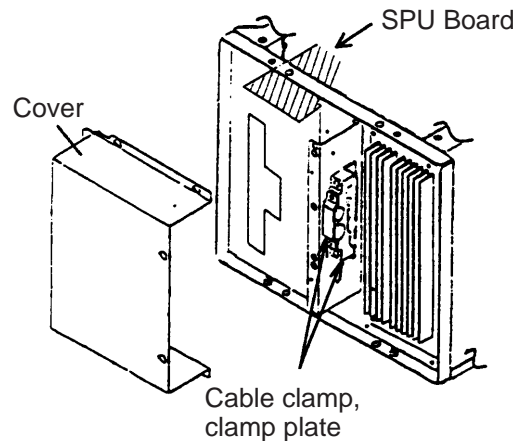
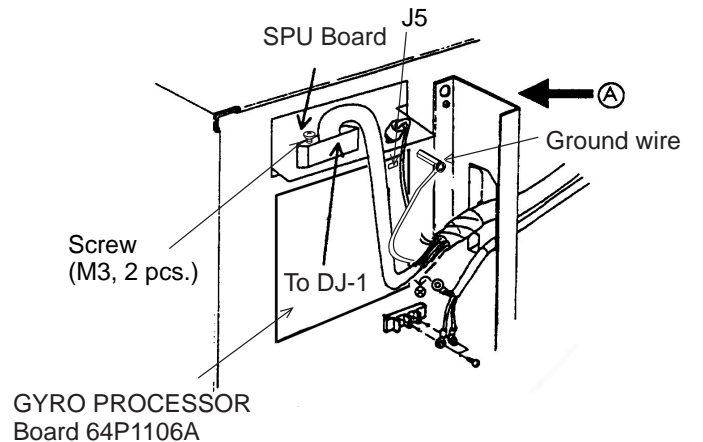

Figure 2-9 Display unit, rear view

1. Unfasten the cover.
2. Unfasten the clamping plate from the cable clamp.
3. Lay the copper tape part (armor part for signal cable with armor) of the signal cable and anticorrosive shield part of power cable in the cable clamp and then fasten with the clamping plate. For cables of optional equipment, loosen M6x35 bolt (2 pcs.) on cable clamp, lay cables in appropriate location in clamp and then tighten clamp.



\* Lay gyrocompass signal cable beneath cables of optional equipment.\*

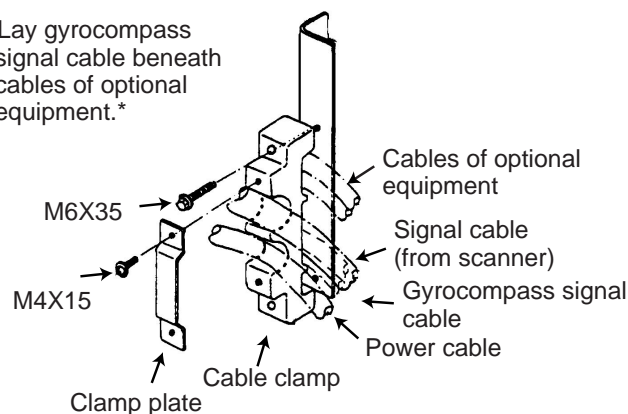
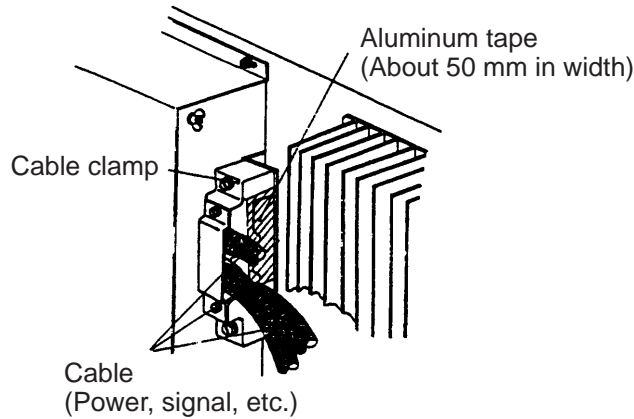

Figure 2-10 Cable clamp at rear of display unit

4. Connect wiring to the SPU Board as shown in the interconnection diagram and Chapter 3. Fasten shields of cables to chassis.
5. Cover the cable clamp with aluminum tape (about 50 mm in width) to keep foreign objects out of the display unit.



*Figure 2-11 Covering the cable clamp with aluminum tape*

## Ground

Run a ground wire (IV-8sq or equivalent) between ground terminal on the display unit and ship's superstructure.

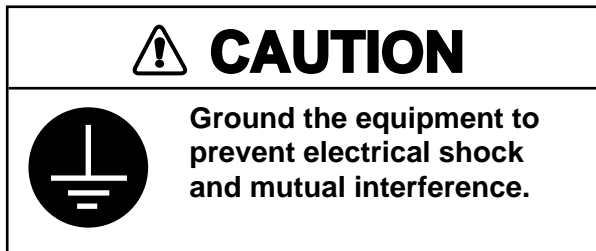

## 2.3 Power Supply Unit

Two cables run to the Power Supply Unit PSU-002: the power cable (250V-DPYC-3.5) from AC power supply and the signal cable (660V-MPYCY-16) from the scanner unit.

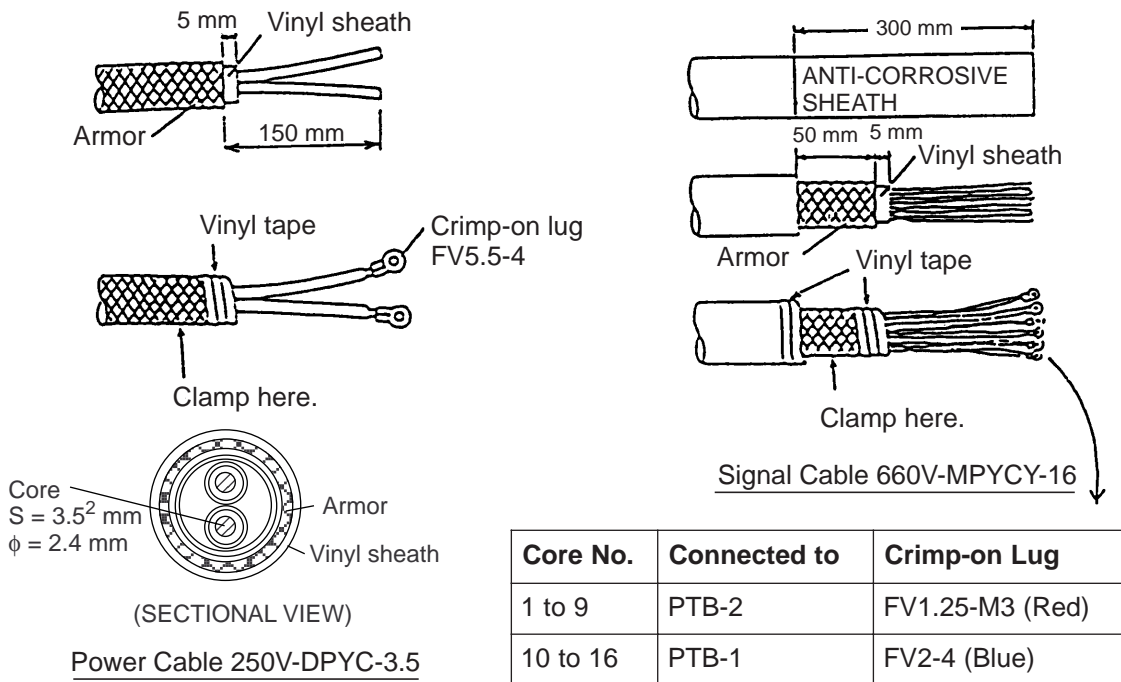

Figure 2-12 Fabrication and connection of power cable and signal cable

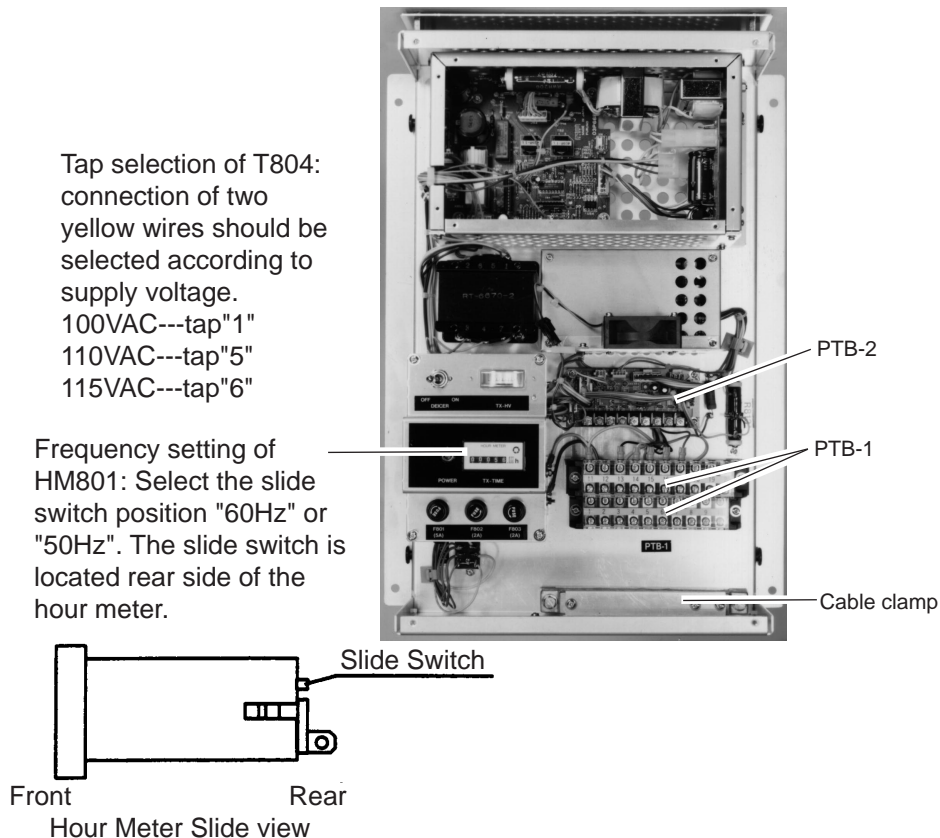
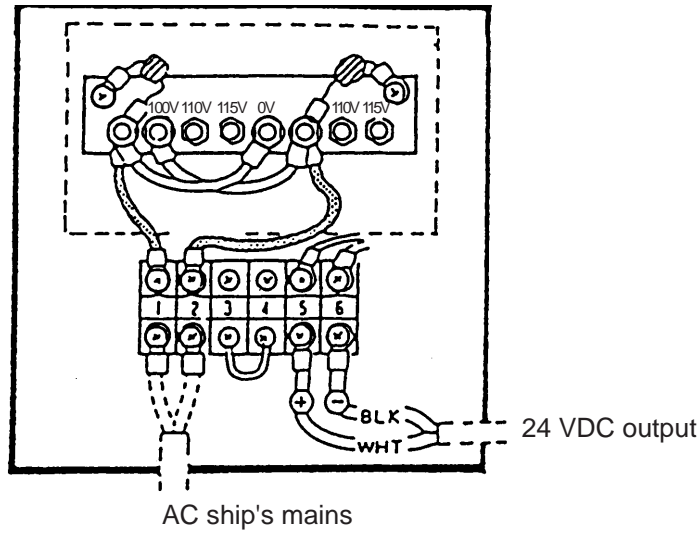

Figure 2-13 Power supply unit PSU-002



## 2.4 Installation and Connection of Rectifier Unit

For operation from ship's mains of 100/110/115/220/230 VAC, the rectifier unit RU-3424 is required. The rectifier unit can be installed in any dry, well-ventilated place. Connect AC ship's mains to the rectifier as below.



Connections for 100 VAC ship's mains

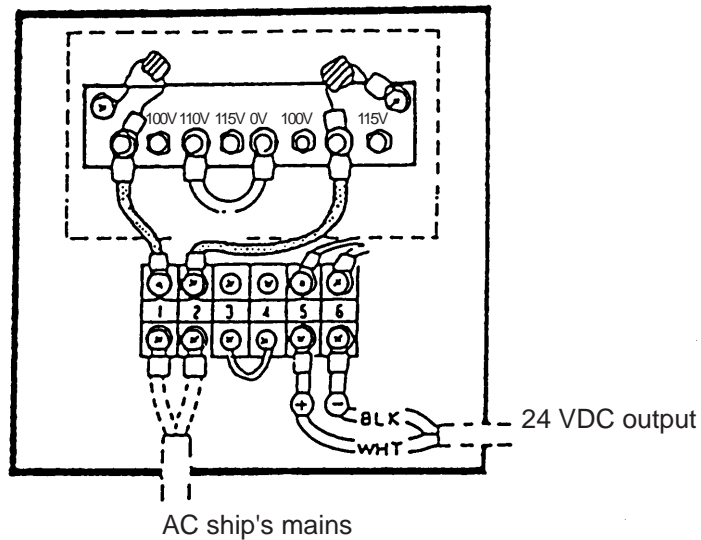

Connections for 220 VAC ship's mains

*Figure 2-14 Rectifier unit connections*

# EXTERNAL SIGNAL INPUT, OUTPUT

## 3.1 Input From External Equipment

Table 3-1 gives the name, number, connector type and connectable equipment for equipment connectable to the SPU Board. Asterisk-marked connectors in the figure below shows cables (S03-55-5: XH-5P connector at one end, two pair, vinyl sheath) which FURUNO can optionally supply.

XH Connector Wiring

Term. No.	Color	
1	BRN	Pair
2	RED	
3	ORG	Pair
4	YEL	
5	BLK	

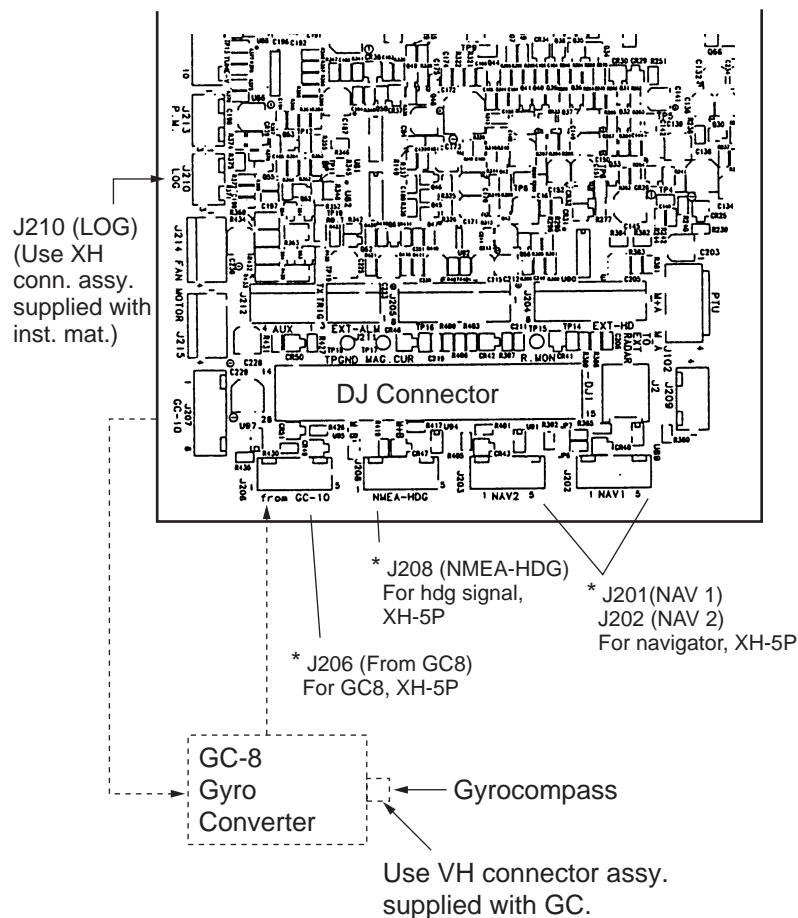
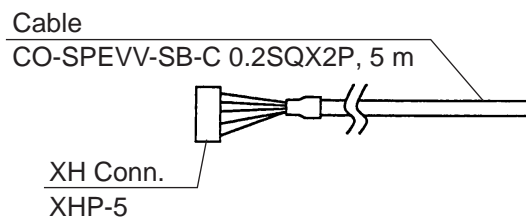

Figure 3-1 Location of input connectors on the SPU Board

*Table 3-1 External signal input connector (SPU Board)*

Signal Name	Conn. Name	Conn. No.	Conn. Type	Connectable Equip.	Remarks
Slave display	—	J205	NH, 8 pin	Main radar	
BRG signal	to GC-10	J207	XH, 6 pin	GC-8	AD-10 format
HDG signal	from GC-10	J206	XH, 5 pin	GC-8, AD-10S, AD-100	NMEA format
	NMEA-HDG	J208	XH, 5 pin	C-2000	(Note 1)
Speed log signal	LOG	J210	XH, 3 pin	DS-30, DS-70, MF-220, CI-60	200 pulses/nm, etc.
Nav data (L/L. WP, Time, TDs, Course, Depth, Water Temperature)	NAV 1	J202	XH, 5 pin	GP-3100M2, GP-50M2, GP-188, FCV series, T-2000, TI-20	
Depth, Water temp.	NAV 2	J203	XH, 5 pin		

**Note 1:** HDT, VHW, HDG, HDM. NMEA-HDG connector also accepts, water temperature and water depth data (in lieu of heading signal).

### 3.2 Output to External Equipment

Table 3-2 describes output connectors on the SPU Board.

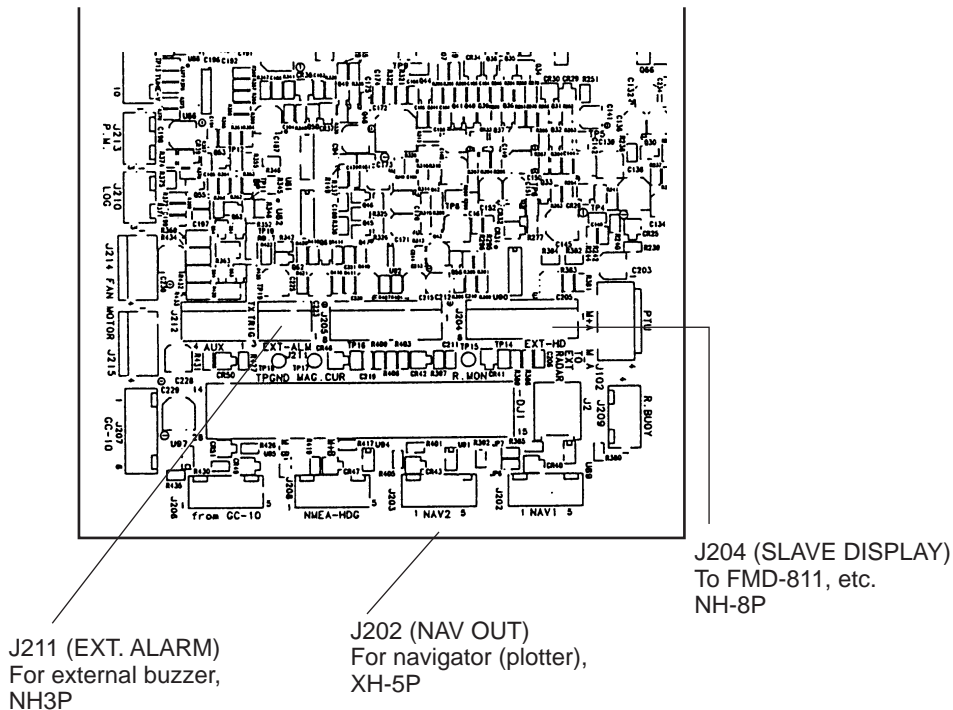

*Figure 3-2 Location of output connectors on the SPU Board*

*Table 3-2 External signal output connector (SPU Board)*

Signal Name	Conn. Name	Conn. No.	Conn. Type	Connectable Equip.	Remarks
Remote display	EXT-HD	J204	NH, 8 pin	FMD-811, FMD-8010 <i>(Note 1)</i>	Heading, bearing video, true trigger
Buzzer signal	EXT ALARM	J211	NH, 3 pin	OP03-21-3 Speaker w/amp	Buzzer drive signal Signal for speaker
Radar signal (serial data)	NAV OUT	J202	NH, 5 pin	To GPS, navigator	NMEA0183 \$ RATLL \$ RARSD

**Note 1:** Display unit of FR-1500 MARK-2 series, FR-7041, FR-7111 may also be used as a remote display.

### 3.3 Connection of External Buzzer

An external speaker or buzzer can be connected to this radar via an amplifier circuit (local supply), as shown in the figure below. Because connector J211 is used for the internal speaker unplug it and connect the connector from the external speaker to J211. Ground the amplifier to nearby connector's ground terminal.

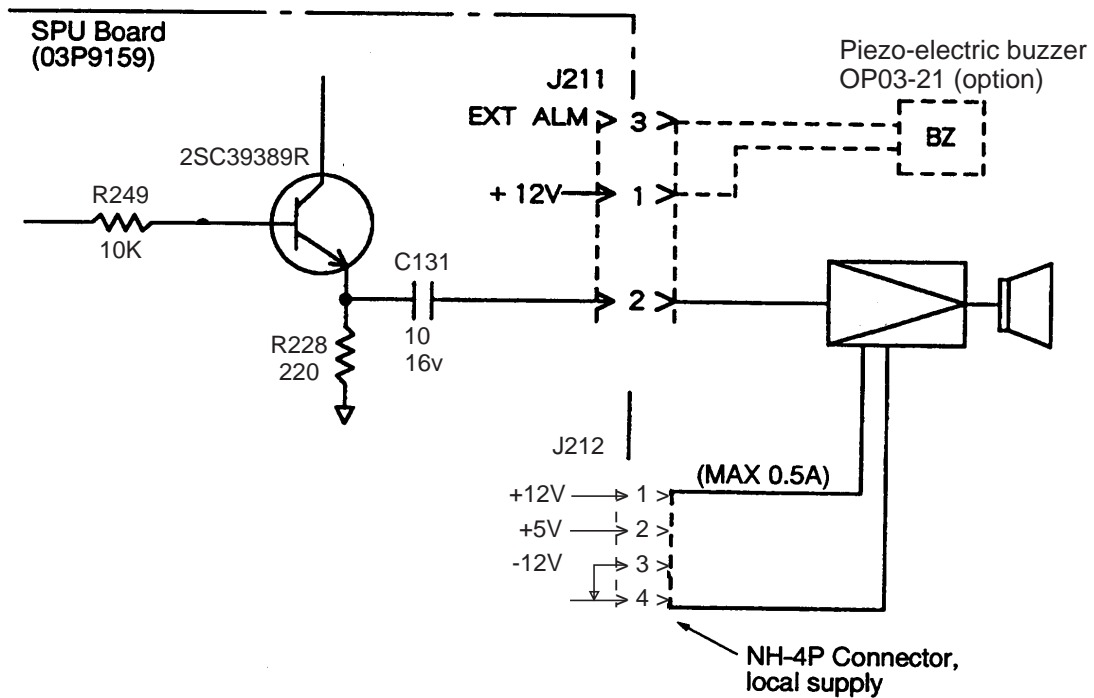

*Figure 3-3 Connection of external buzzer*

### 3.4 Data Sentences

*Table 3-3 NMEA-0183 input sentences*

Item	Receive Sentence
Speed (knots only)	VTG>RMC>RMA
Heading (true)	HDT>HDG(*)>HDM(*)>VHW>VHW(*)
Heading (magnetic)	HDM>HDG(*)>HDT(*)>VHW>VHW(*)
Course (true)	VTG>VTG(*)>RMC>RMA
Course (magnetic)	VTG>VTG(*)>RMC>RMA
Waypoint (range, bearing)	BWR>BWC>RMB
Position	GGA>RMC>RMA>GLL
TD	RMA>GLC>GTD
Time	ZDA
Water Temperature	MDA>MTW
Water Depth	DPT>DBK>DBS>DBT
Magnetic Variation	HDG
Magnetic Deviation	HDG>RMC>RMA

\*: Calculated alternately in true and magnetic using magnetic variation data.

*Table 3-4 Tx NMEA-0183 output sentences*

	Receive Sentence
Target Position (Cursor latitude, longitude)	RATLL
Radar system data*	RARSD

\* Range and bearing of origin mark, EBL bearing, VRM range, range and bearing of cursor, etc.

# INITIALIZATION AND ADJUSTMENT

The display unit RDP-120 can be used as a sub display. If the sub display is installed, set heading alignment, sweep timing, video signal level, antenna height and STC slope for each display unit.

## 4.1 Tuning

1. Press the [MENU] key.
2. Press the [0] key twice to select OTHER.

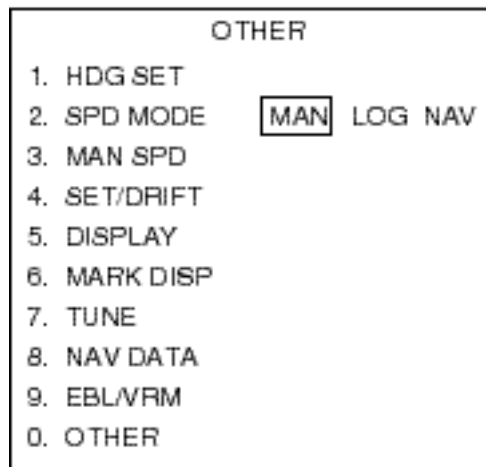

*Figure 4-1 OTHER menu*

3. Press the [7] key twice followed by the [ENTER/SELECT] key to tune. "AUTO TUNE" appears on the screen while the radar is tuning and goes off when tuning is completed. (This procedure records both peak voltage and fine automatic tuning for the injector display.)

## 4.2 Accessing Menus for Initialization and Adjustment

1. Turn on the power while pressing the GAIN control.
2. Press the [MENU] key.
3. Press the [0] key four times.
4. Press the [6] key twice to select INSTALL. The SET UP 1 menu appears.
5. Select desired menu referring to the installation menu tree below.

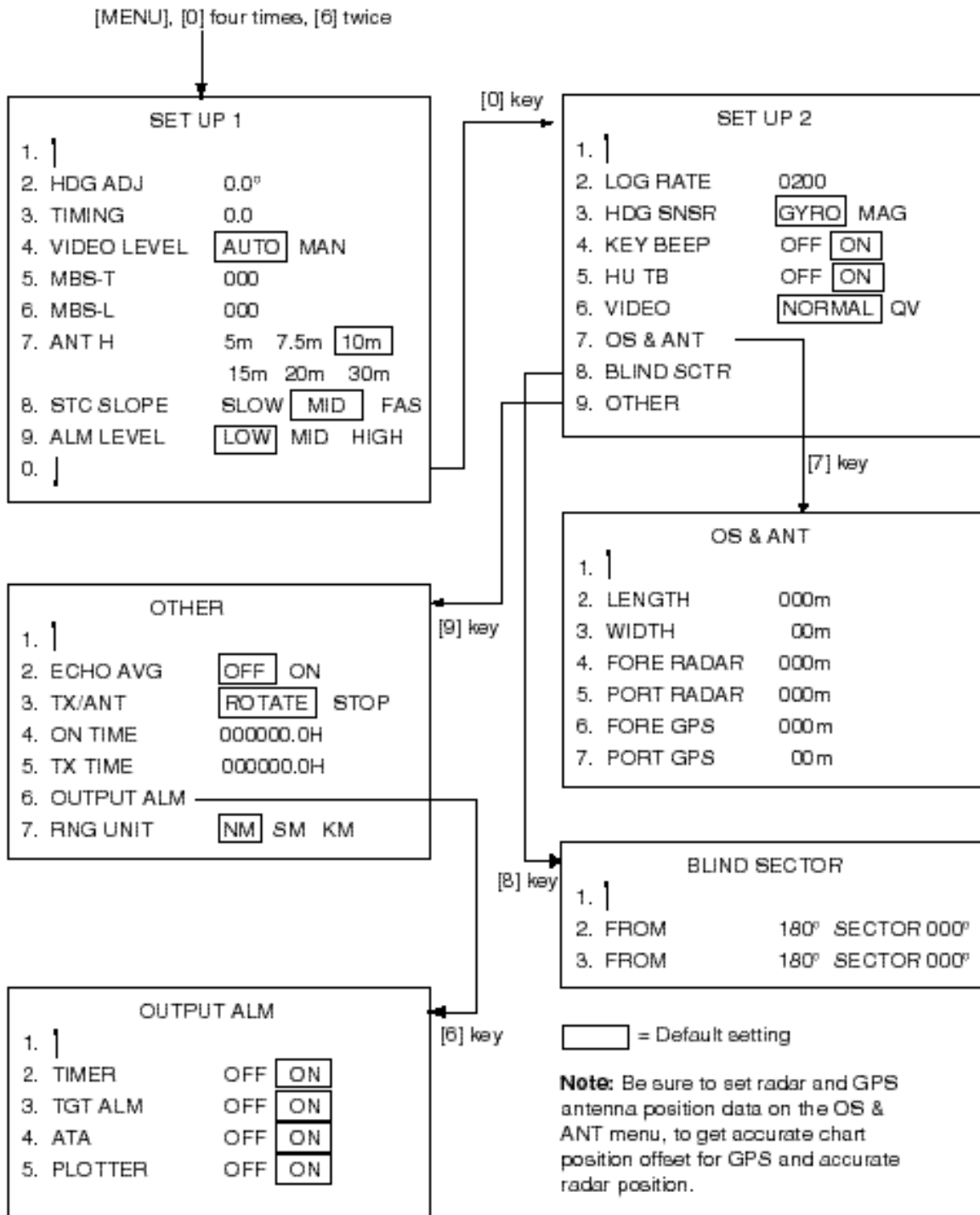

Figure 4-2 Installation menu tree

## Restoring default settings

1. Press and hold down the GAIN control while pressing the [MENU] key five times.
2. Press the [4] key to twice to select FACTORY DEFAULT.
3. Press the [ENTER/SELECT] key to finish.

## 4.3 Heading Alignment

You have mounted the scanner unit facing straight ahead in the direction of the bow. Therefore, a small but conspicuous target dead ahead visually should appear on the heading line (zero degrees).

In practice, you will probably observe some small bearing error on the display because of the difficulty in achieving accurate initial positioning of the scanner unit. The following adjustment will compensate for this error.

Set heading alignment for both main unit and sub display.

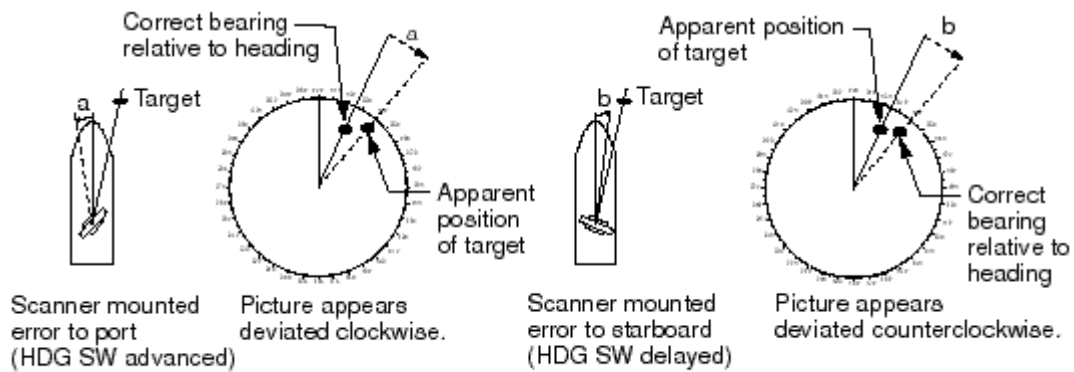

Figure 4-4 Heading alignment

1. Press [MENU] [0] [0] [0] [0] [6] [6] [2] [2] to select HDG ADJ from the SET UP 1 menu.
2. Select a target echo (by gyrocompass, for example) at a range between 0.125 and 0.25 nm, preferably near the heading line.
3. Operate the EBL control to bisect the target echo with the heading line. (The value shown on the display is scanner position in relation to ship's bow.)
4. Press the [ENTER/SELECT] key to finish.



## 4.4 Adjusting Sweep Timing

Sweep timing differs with respect to the length of the signal cable between the scanner unit and the display unit. Adjust sweep timing for both main display and sub display (if installed). Adjust sweep timing at installation to prevent the following symptoms:

- The echo of a “straight” target (for example, pier), on the 0.25 nm range, will appear on the display as being pulled inward or pushed outward. See Figure 4-5.
- The range of target echoes will also be incorrectly shown.

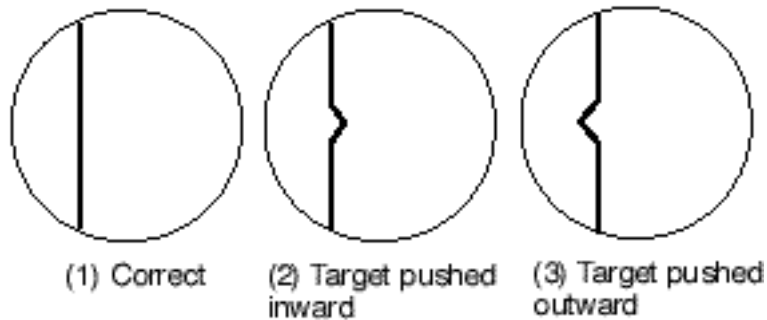

*Figure 4-5 Examples of correct and incorrect sweep timings*

1. Press [MENU] [0] [0] [0] [0] [6] [6] [3] [3] to select TIMING from the SET UP 1 menu.
2. Transmit on the 0.25 nm range.
3. Adjust radar picture controls to display picture properly.
4. Select a target echo which should be displayed straightly.
5. Adjust the VRM control to straighten the target echo.
6. Press the [ENTER/SELECT] key to finish.

## 4.5 Adjusting Video Signal Level

When the signal cable is very long, the video amplifier input level decreases, shrinking target echoes. To prevent this, adjust the video level, either automatically or manually. Adjust it after adjusting tuning and sweep timing and do it on long range. Adjust video signal level for both main display and sub display (if installed).

### Automatic adjustment

1. Turn off the A/C AUTO control
2. Transmit on long range.
3. Display the SET UP 1 menu.
4. Press the [4] key twice to select AUTO from the VIDEO LVL field.
5. Press the [ENTER/SELECT] key to automatically adjust the video level. The message "Adjusting video level. Please wait." appears. When the adjustment has been completed a beep sounds.
6. Connect an oscilloscope to TP6 on the pcb 03P9230 (display unit) and measure main bang signal level. It should be 4.0 Vpp  $\pm$ 0.2 V. If it is not, within that range redo steps 4 and 5 above.

### Manual adjustment

If the video signal level could not be adjusted automatically, manually adjust it as follows:

1. Do steps 1-3 in automatic tuning.
2. Press the [4] key twice to select MAN from the VIDEO LVL field.
3. Press the [ENTER/SELECT] key.
4. Connect the oscilloscope to TP6 on the pcb 03P9230. Operate the EBL rotary control while pressing and holding down the HL OFF control so the main bang level is 4.0 Vpp  $\pm$ 0.2 V.

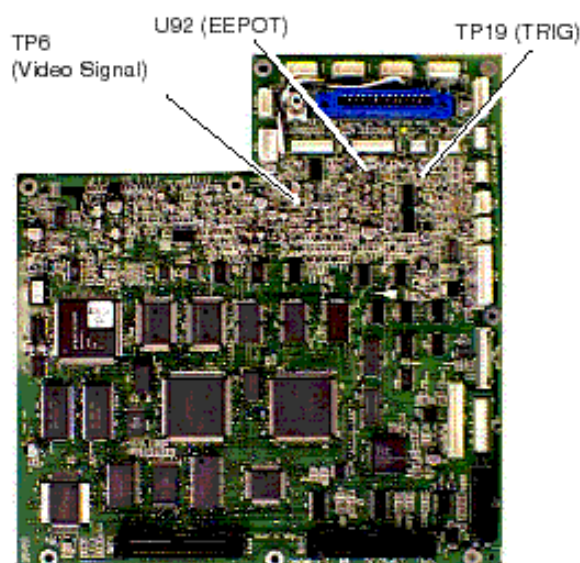

Figure 4-6 pcb 03P9230

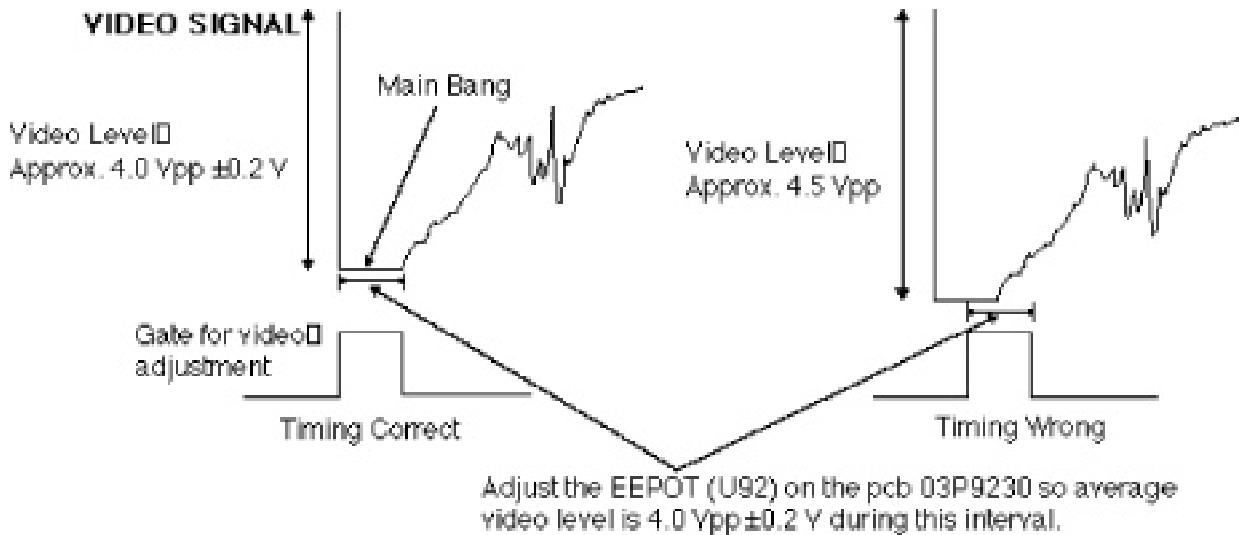

Figure 4-7 Video signal timing

## 4.6 Suppressing Main Bang

If the main bang appears at the screen center, suppress it as follows:

1. Turn on the power. Transmit on a long range and then wait ten minutes.
2. Adjust [GAIN] control to show a slight amount of noise on the display.
3. Select the 0.25 nm range. Adjust the [A/C SEA] control to suppress sea clutter.
4. Press [MENU] [0] [0] [0] [0] [6] [6] to open the SET UP 1 menu.
5. Press the [5] key to select MBS-T.
6. Adjust the VRM control to adjust timing and then press the [ENTER/SELECT] key.
7. Press the [6] key to select MBS-L.
8. Adjust the VRM control to adjust level and then press the [ENTER/SELECT] key.

## 4.7 Confirming Magnetron Heater Voltage

Magnetron heater voltage is adjusted at the factory with a 15 m signal cable. Therefore, when the signal cable is longer than 15 m, confirm that magnetron heater voltage is within the prescribed rating as follows:

1. Disconnect P821 from the scanner unit.
2. Press [MENU] [0] [0] [0] [0] [6] [6] [0] [0] [9] [9] to open the OTHER menu.

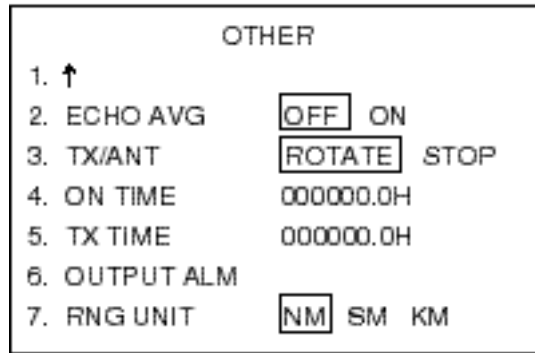

Figure 4-8 OTHER menu

3. Press the [3] key several times to select STOP from the TX/ANT field.
4. Set the range to 0.125 nm.
5. Connect a multimeter, set to the 10 VDC range, between J829 #1 (+) and #2 (-) in the scanner unit.
6. Adjust the position of the sliding contact R812 to show a value between 7.0 V and 7.6 V on the multimeter.
7. Remove the TX-HV fuse (F801, 0.5A) from the power supply unit.
8. Transmit on maximum range.
9. Adjust the position of the sliding contact R811 to show a value between 4.7 V and 5.3 V on the multimeter.
10. Insert TX-HV fuse F801.
11. Set TX/ANT to ROTATE on the OTHER menu.

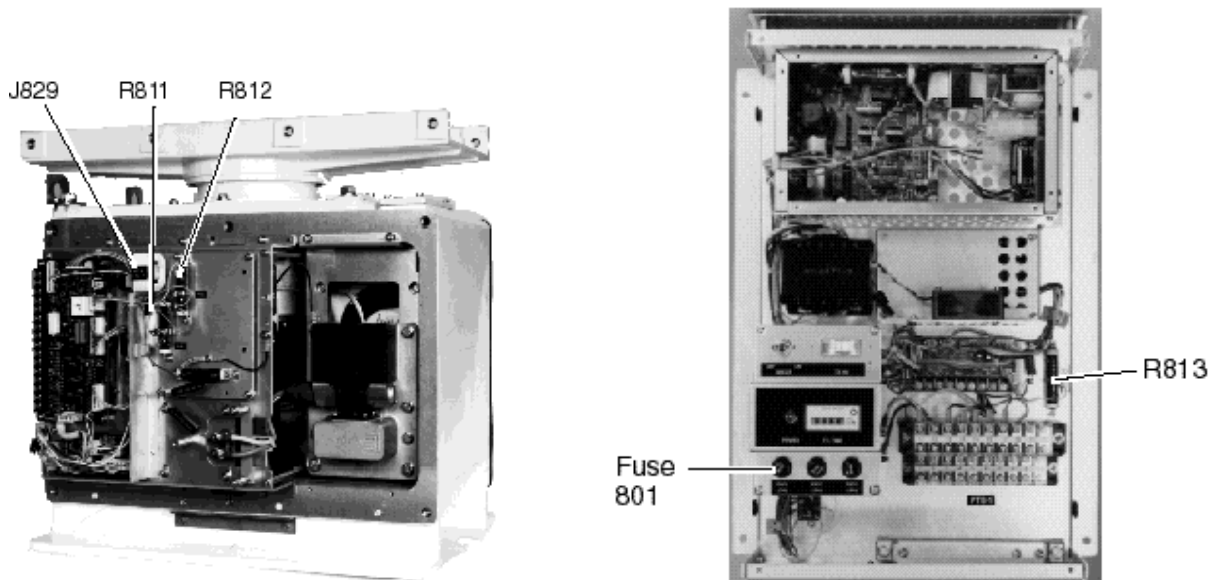

Photo No. 2914

Figure 4-9 Scanner unit, power supply unit PSU-002

12. Press the [ENTER/SELECT] key to finish.

13. Turn on the ANT MOTOR SW on the scanner unit (Refer to figure1-4).

**Note:** When the length of the cable between the scanner unit and the power supply unit is more than 60 meters, the magnetron heater voltage may not reach the lower limit due to voltage drop. If this is the case, increase the voltage with the sliding contact R813 in the power supply unit, and readjust with R811, R812 in the scanner unit.

## 4.8 Initial Settings

The SETUP menus (two), OTHER menu, OS & ANT menu, OTHER menu, BLIND SECTOR menu and OUTPUT ALM menu setup the radar according to expected usage, authorities specification, ship's characteristics, operator's preference, etc. Set items on each menu in accordance with regulations/operator's preference. After entering settings, reset the power.

### SET UP 1 menu

Keying sequence: [MENU] [0] [0] [0] [0] [6] [6]

**HDG ADJ:** Aligns heading.

**TIMING:** Adjusts sweep timing.

**VIDEO LEVEL:** Adjusts video amplifier level automatically or manually.

**MBS-T, MBS-L:** Suppresses main bang in level and timing

**ANT H:** Enter height of scanner above water. Select from 5 m, 7.5 m, 10 m, 15 m, 20 m, or more than 30 m. Set height of scanner for both main display and sub display (if installed).

**STC SLOPE:** Selects level of STC affect; Slow, Medium or Fast.  
Set STC slope for both main display and sub display (if installed).

**ALM LEVEL:** Select echo strength which triggers the guard zone alarm.

### SET UP 2 menu

Keying sequence: [MENU] [0] [0] [0] [0] [6] [6] [0] [0]

**LOG RATE:** Enter speed log's pulse rate.

**HDG SNSR:** Select type of heading sensor connected to the radar: gyrocompass or magnetic compass.

**KEY BEEP:** Turns key beep on/off.

**HU TB:** Enables/disables the heading up true bearing presentation mode.

**VIDEO:** Set to NORMAL (analog signal) for normal use. Select QV (Quantized Video) to adjust ARP.

**OS & ANT:** See OS & ANT menu.

**BLIND SCTR:** Sets area (up to 2) where no radar pulses will be transmitted. For example, set the area where an interfering object at the rear of the scanner would produce a dead sector (area where no echoes appear) on the display. To enter an area, select ON and enter relative bearing range of the area.

## OTHER menu

Keying sequence: [MENU] [0] [0] [0] [0] [6] [6] [0] [0] [9] [9]

**ECHO AVG:** Echo averaging can be turned on without gyrocompass connection.

**TX/ANT:** Set to ROTATE in normal use. STOP enables transmission state without scanner rotation.

**ON TIME, TX TIME:** Shows number of hours the radar has been turned on and transmitted, respectively. Value can be changed.

**OUTPUT ALARM:** See OUTPUT ALM menu.

## OUTPUT ALM menu

Keying sequence: [MENU] [0] [0] [0] [0] [6] [6] [0] [0] [9] [9] [6] [6]

Selects which alarm signal(s) to output; timer, target alarm, ATA alarm, plotter alarm.

## OS & ANT menu

Keying sequence: [MENU] [0] [0] [0] [0] [6] [6] [0] [0] [7]

**LENGTH:** Enter ship's length.

**WIDTH:** Enter ship's width.

**FORE RADAR:** Enter distance from radar scanner to fore.

**PORT RADAR:** Enter distance from radar scanner to port.

**FORE RADAR:** Enter distance from GPS antenna to fore.

**PORT RADAR:** Enter distance from GPS antenna to port.

**Note:** When the radar antenna distances are entered the same distances are copied to the distances for the GPS antenna. Change the GPS antenna distances to actual distances.

## 4.9 Changing Input Voltage

To power the radar by 220 VAC, modify jumpers on the AC power supply board, and change the fuses (F1351, F1352) from 10A to 5A.

1. Turn off the display unit.
2. Remove the cover of the display unit.

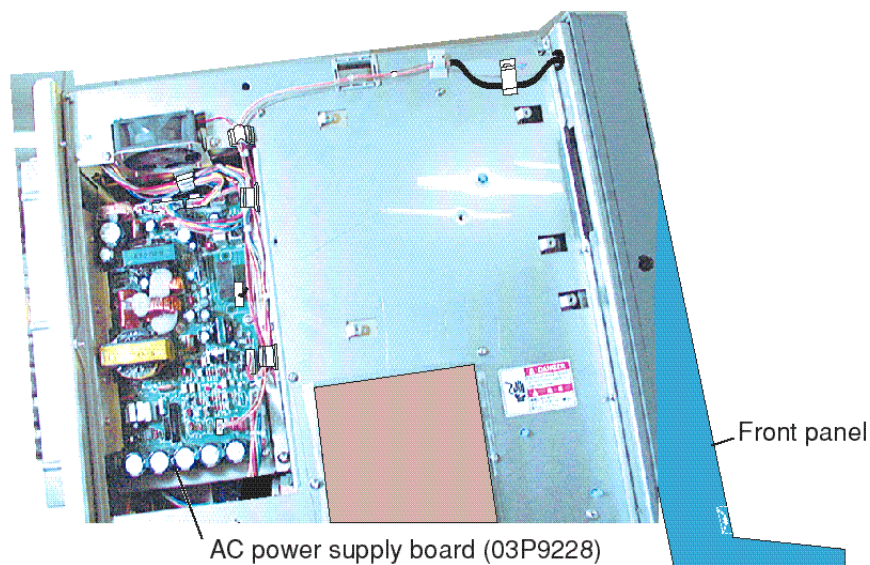

Figure 4-10 Display unit, left side view

3. Unfasten five screws to remove the heat sink.
4. Unfasten three screws to remove the AC power supply board.
5. Remove all connectors from the AC power supply board.
6. Remove the heat sink with AC power supply board from the display unit.

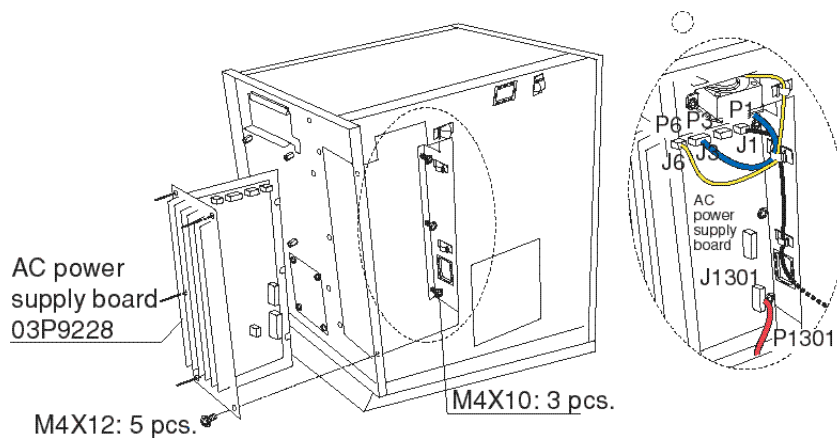
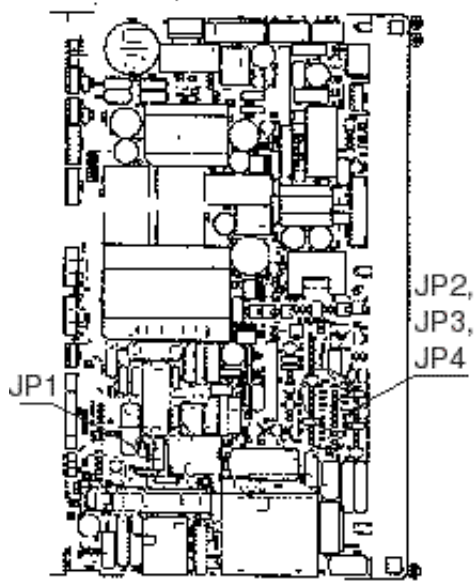

Figure 4-11 Display unit, rear view

7. Open jumpers JP1, JP2 and JP3 on the AC power supply board. Short JP4 on the AC power supply board.



AC power supply board 03P9228

Ship's main	JP1	JP2	JP3	JP4
100 VAC	short	short	short	open
220 VAC	open	open	open	short

Figure 4-12 AC power supply board, jumper settings for 220 VAC

8. Reassemble the display unit.  
 9. Change two fuses from 10A to 5A on the rear panel.

Ship's main	F1351	F1352
100 VAC	10A	10A
220 VAC	5A	5A



# OPTIONAL EQUIPMENT



## WARNING

Turn off the radar before installing optional equipment.

The display unit contains high voltage components which can shock, burn or cause death. Allow residual charge to subside (2-3 min.) in display unit before opening the cover.



## CAUTION

Check that the radar display unit is properly connected.

The ARP-17 cannot perform its intended functions unless the radar display unit is properly connected. Also, be sure the radar is not being interfered by other equipment and is not giving interference to other equipment.

## 5.1 Gyro Converter GC-8

### Gyro converter installation kit

Name	Type	Code No.	Qty
GYRO CONVERTER Board	64P1106	004-412-200	1
Washerhead Screw	M3 x 8	008-456-404	5
PH-XH Connector	03-1761 (14P-6P)	008-456-130	1
NH-XH Connector	03-1762 (5P-5P)	008-456-140	1
Label	64-014-2021-1	100-132-701	1
VH Connector Assy.	03-1763 (5P)	008-456-150	1
VH Connector Assy.	03-1764 (3P)	008-456-160	1
Spare Fuses	FGMB 2A 250V	000-122-000	8

**Note:** Other parts may be contained in the kit. These parts are not to be used; they may be discarded.

## Installation and wiring

Install the GYRO CONVERTER Board in the display unit as follows:

1. Open the rear cover.

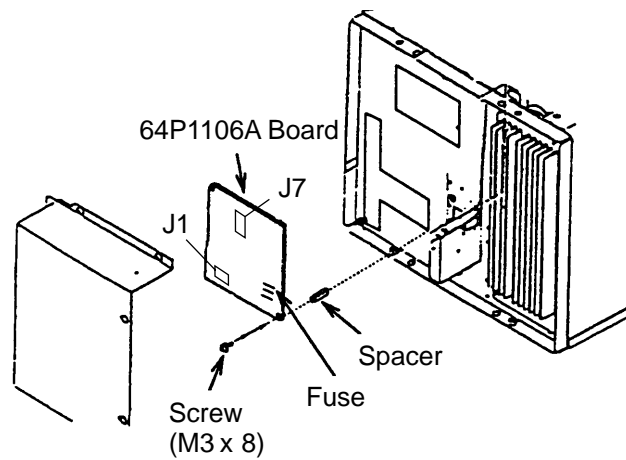

Figure 5-1 Display unit, rear view

2. Fasten the GYRO CONVERTER Board to the display unit so that the battery on the board is at the top left corner.
3. Connect the GYRO CONVERTER Board to the SPU Board as below. Use the connector assemblies attached to J206 and J207 on the SPU Board. Do not use the connector assemblies supplied with Gyro Converter kit.

GYRO CONVERTER Board	SPU Board
J1 (14P)	J207 (6P)
J7 (5P)	J206 (5P)

4. Confirm gyrocompass specifications and set up the DIP switches and jumper wires on the GYRO CONVERTER Board according to gyrocompass connected:
  - Setting jumper wires and DIP switches by gyrocompass specifications: page 5-4
  - Setting jumper wires and DIP switches by make and model of gyrocompass: page 5-6
  - Location of jumper wires and DIP switches: page 5-7
5. Solder the gyrocompass cable to the VH connector assemblies (supplied) and connect to the GYRO CONVERTER Board as shown in the table below.

### Connection of gyrocompass cable

Connector		Step Type	Synchro Type
J4	#1	S1	S1
	#2	S2	S2
	#3	S3	S3
	#4	-	-
	#5	F. G.	F. G.
J5	#1	-	R2
	#2	COM	R1
	#3	F. G.	F. G.

6. Attach the instruction label (supplied) on the inside of the rear cover.

### Connection of external power supply

An external power supply is necessary when the repeater signal is step-by-step type and the step voltage is below 20V or output voltage is less than 5 W.

1. Cut jumper wire JP1 on the GYRO CONVERTER Board when an external power supply is used.
2. Connect gyro cable and power cable as shown below.

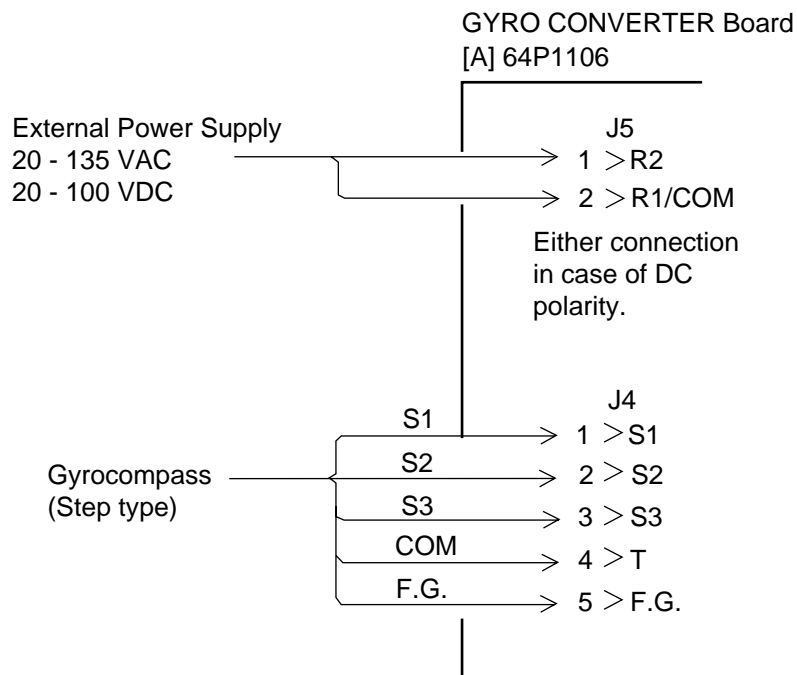

Figure 5-2 Connection of external power supply to GYRO CONVERTER Board

# DIP switch, jumper wire settings

## Default setting

The default setting of all DIP switches is off and all jumpers wire are set to “#1.” (Note that jumper wire JP1 is set at #1, #2, and #3.) In those settings the gyrocompass having the following characteristics can be directly connected; modification of the GYRO CONVERTER Board is not necessary.

- AC synchronous signal: 50/60 Hz
- Rotor voltage: 60 V to 135 V AC
- Stator voltage: 60 V to 135 V AC
- Gear ratio: 360x
- Supply voltage: 30 V to 135 V AC

If the specifications of the gyrocompass differ from those mentioned above, change jumper wire and DIP switches settings on the GYRO CONVERTER Board. Settings may be changed according to gyrocompass specifications or make and model of gyrocompass (see page 5-6). For the location of DIP switches and jumper wires, see page 5-7.

## Setting method 1: by gyrocompass specifications

### 1) Gyrocompass type

Gyrocompass type	SW 1-4	SW 1-5	SW 1-6	JP1
AC synchronous	OFF	OFF	OFF	#1, #2, #3
DC synchronous	OFF	OFF	OFF	#2, #3, #4
DC step	ON	OFF	OFF	#4, #5, #6
Full-wave pulsating current	OFF	ON	OFF	#4, #5, #6
Half-wave pulsating current	ON	ON	OFF	#4, #5, #6

### 2) Frequency

Frequency	SW 1-7	SW 1-8	Remarks
50/60 Hz	OFF	OFF	AC synchronous pulsating current
400 Hz	ON	OFF	AC synchronous pulsating current
500 Hz	OFF	ON	AC synchronous pulsating current
DC	ON	ON	DC synchronous DC step

### 3) Rotor voltage (between R1 & R2)

Rotor voltage	SW 2-1	JP3
20 V to 45 VAC	ON	#2
30 V to 70 VAC	OFF	#2
40 V to 90 VAC	ON	#1
60 V to 135 VAC	OFF	#1

### 4) Stator voltage (between S1 and S2)

Stator voltage	SW 2-2	SW 2-3	JP2
20 V to 45 VAC, or 20 V to 60 VDC	ON	OFF	#2
20 V to 45 VAC, or 20 V to 60 VDC	OFF	OFF	#2
40 V to 90 VAC	ON	OFF	#1
60 V to 135 VAC	OFF	OFF	#1

### 5) Ratio

Ratio	SW1-1	SW 1-2	SW1-3
360x	OFF	OFF	OFF
180x	ON	OFF	OFF
90X	OFF	ON	OFF
36X	ON	ON	OFF

### 6) Supply voltage

Supply voltage	JP4	JP5
20 V to 45 VAC, or 20 V to 60 VDC	#2	#2
30 V to 135 VAC, or 40 V to 100 VDC	#1	#1

### 7) AD-10 format data

#### Tx interval

Select data transmitting interval for ports 1 to 6 by jumper wires JP6 and JP7.

**Note:** The Tx interval is available in 25 ms or 200 ms. 25 ms is for radar; 200 ms is for all other equipment.

### 8) NMEA-0183

#### Tx interval

Tx interval	SW2-4
2 seconds	ON
1 second	OFF

## Setting method 2: by make and model of gyrocompass

Maker	Models	Specification	SW 1-1	SW 1-2	SW 1-3	SW 1-4	SW 1-5	SW 1-6	SW 1-7	SW 1-8	SW 2-1	SW 2-2	SW 2-3	JP1	JP2	JP3	JP4	JP5	
FURUNO	GY-700	DC step 100V 180x 5-wire, open collector	ON	OFF	OFF	ON	OFF	OFF	ON	ON	-	OFF	OFF	#4, #5,#6	#2	-	#1	#1	
Anschutz	Standard 2,3	AC synchronous 50/60Hz Rotor voltage: 50/60V Stator voltage: 22V 360x	OFF	OFF	OFF	OFF	OFF	OFF	OFF	OFF	OFF	ON	OFF	#1, #2,#3	#2	#2	#1	#1	
	Standard 4,6	AC synchronous 50/60Hz Rotor voltage: 50/60V Stator voltage: 90V 360x	OFF	OFF	OFF	OFF	OFF	OFF	OFF	OFF	OFF	OFF	OFF	#1, #2,#3	#2	#1	#1	#1	
	Standard 20	DC step 35V 180x COM(-), 3-wire(+)	ON	OFF	OFF	ON	OFF	OFF	ON	ON	-	ON	OFF	#4, #5,#6	#2	-	#2	#2	
Yokogawa Navtec (Plait type)	C-1/1A/2/3 A-55, B-55	AC synchronous 50/60Hz Rotor voltage: 50/60V Stator voltage: 22V 360x	OFF	OFF	OFF	OFF	OFF	OFF	OFF	OFF	OFF	ON	OFF	#1, #2,#3	#2	#2	#1	#1	
	CMZ-700	DC step 24V 180x COM(+), 3-wire(-)	ON	OFF	OFF	ON	OFF	OFF	ON	ON	-	ON	OFF	Remove	#2	-	*	*	
	CMZ-250X/ 300X/500	DC synchronous 360x	OFF	OFF	OFF	OFF	OFF	OFF	OFF	ON	ON	-	ON	OFF	Remove	#2	-	*	*
		DC step 35V 180x COM(+), 3-wire(-)	ON	OFF	OFF	ON	OFF	OFF	OFF	ON	ON	-	ON	OFF	#4, #5,#6	#2	-	#2	#2
	CMZ-100/200/ 300 C-1Jr,D-1Z/1/3 IPS-2/3	AC synchronous 50/60Hz Rotor voltage: 100V Stator voltage: 90V 360x	OFF	OFF	OFF	OFF	OFF	OFF	OFF	OFF	OFF	OFF	OFF	OFF	#1, #2,#3	#1	#1	#1	#1
CMZ-50 Note	step 35V 180x COM(+), 3-wire(-)	ON	OFF	OFF	ON	OFF	OFF	OFF	ON	ON	-	ON	OFF	Remove	#2	-	*	*	
Plait	NAVGAT II/III	AC synchronous 50/60Hz Rotor voltage: 50/60V Stator voltage: 68V 360x	OFF	OFF	OFF	OFF	OFF	OFF	OFF	OFF	OFF	OFF	OFF	#1, #2,#3	#2	#2	#1	#1	
Tokimec (Sperry type)	ES-1/2/11 GLT-101/102/ 103/106K/107	AC synchronous 50/60Hz Rotor voltage: 100/110V Stator voltage: 90V 36x	ON	ON	OFF	OFF	OFF	OFF	OFF	OFF	OFF	OFF	OFF	#1, #2,#3	#1	#1	#1	#1	
	ES-11A/110 TG-200 PR222R/2000 PR237L/H GM 21	AC synchronous 50/60Hz Rotor voltage: 100/110V Stator voltage: 22V 90x	OFF	ON	OFF	OFF	OFF	OFF	OFF	OFF	OFF	OFF	OFF	#1, #2,#3	#1	#1	#1	#1	
	MK-14 MOD-1/2/T NK-EN,NK-EI	DC step 70V 180x COM(-), 3-wire(+)	ON	OFF	OFF	ON	OFF	OFF	ON	ON	-	OFF	OFF	#4, #5,#6	#2	-	#1	#1	
	SR-130/140	DC step 70V 180x 5-wire, open collector	ON	OFF	OFF	OFF	ON	OFF	OFF	OFF	-	OFF	OFF	#4, #5,#6	#2	-	#1	#1	
	TG-100/5000 PR-357/130/ 140, ES-17 GLT-201/202 /203	DC step 70V 180x COM(+), 3-wire(-)	ON	OFF	OFF	ON	OFF	OFF	ON	ON	-	OFF	OFF	#4, #5,#6	#2	-	#1	#1	
	TG-6000	DC step 24V 180x	ON	OFF	OFF	ON	OFF	OFF	ON	ON	-	ON	OFF	#4, #5,#6	#2	-	#2	#2	
	GM-11	AC synchronous 50/60Hz Rotor voltage: 100V Stator voltage: 90V 90x	OFF	ON	OFF	OFF	OFF	OFF	OFF	OFF	OFF	OFF	OFF	OFF	#1, #2,#3	#1	#1	#1	#1
	SR-120,ES-16 MK-10/20/30	DC step 35V 180x	ON	OFF	OFF	ON	OFF	OFF	ON	ON	-	ON	OFF	#4, #5,#6	#2	-	#2	#2	
Kawasaki	GX-81	AC synchronous 50/60Hz Rotor voltage: 100/110V Stator voltage: 90V 90x	OFF	ON	OFF	OFF	OFF	OFF	OFF	OFF	OFF	OFF	OFF	#1, #2,#3	#1	#1	#1	#1	
Armabrown	MK-10,MKL-1 SERIES1351, MOD-4	DC step 50V 180x COM(+), 3-wire(-)	ON	OFF	OFF	ON	OFF	OFF	ON	ON	-	OFF	OFF	#4, #5,#6	#2	-	#1	#1	
Robertson	SKR-80	DC step 35V 180x COM(-), 3-wire(+)	ON	OFF	OFF	ON	OFF	OFF	ON	ON	-	ON	OFF	#4, #5,#6	#2	-	#2	#2	

\* : Set JP4 and JP5 according to the voltage of the external power supply.

**Note:** If CMZ-50 has 35VDC, set JP1 to #4, #5, #6.

## Location of DIP switches, jumper wires on the GYRO CONVERTER Board

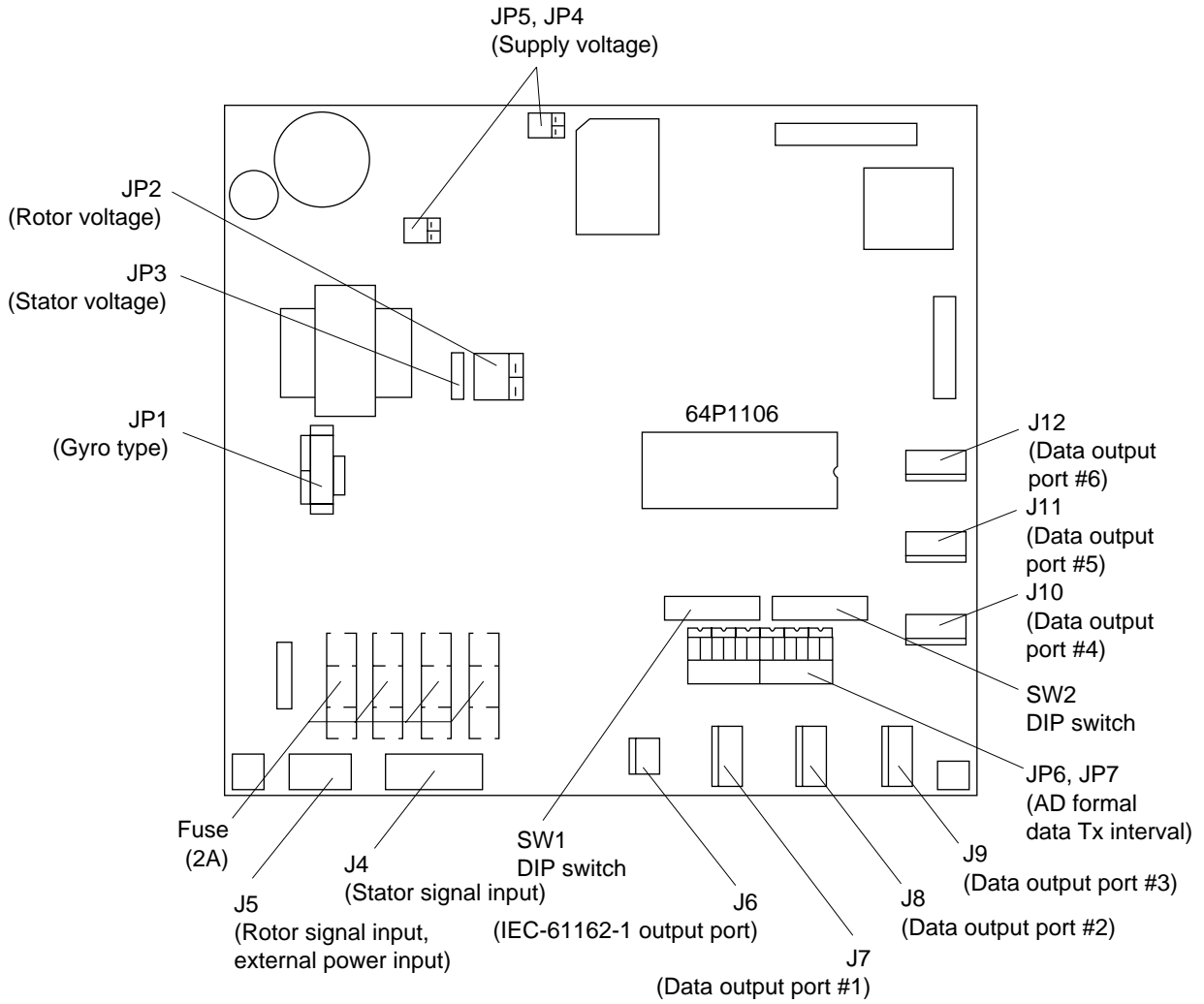
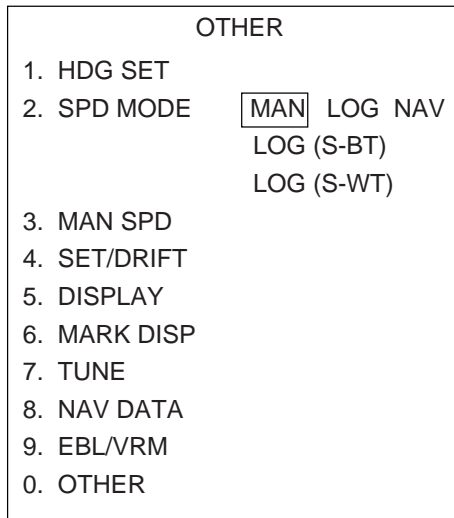

Figure 5-3 GYRO CONVERTER Board

## Setting the heading readout on the radar display

Confirm that the gyrocompass is giving a reliable readout. Then, set the heading readout on the radar display with the gyrocompass readout as follows:

1. Press the [MENU] key.
2. Press the [0] key twice to display the OTHER menu.



*Figure 5-4 OTHER menu*

3. Press the [1] key to select HDG SET.
4. Rotate the EBL rotary control to align the radar's HDG readout with the gyrocompass.
5. Press the [ENTER/SELECT] key to conclude the setting and the [MENU] key to close the menu.

## 5.2 Automatic Tracking Aid ARP-17

### Necessary parts

Contents of ARP-17-2-E installation kit (008-488-840)

Name	Type	Code No.	Qty
ATA Board ARP-17	18P9004A	008-490-940	1
Cable Assy.	HIF6-68D-AA-24-MS	000-135-142	1
Spacer*	SQ-10	000-801-678	8
Toroidal Core	TFC-25-15-12	000-129-693	1
Cable Tie	CV-150	000-570-325	1
Panhead Screw	M3X8	000-881-404	8
Operator's Manual	ARP-17	000-808-575	1

\*: no use



## Installation of ATA Board

1. Unfasten eight screws to detach the cover from the display unit.
2. Fasten the ATA Board to the chassis with seven screws.

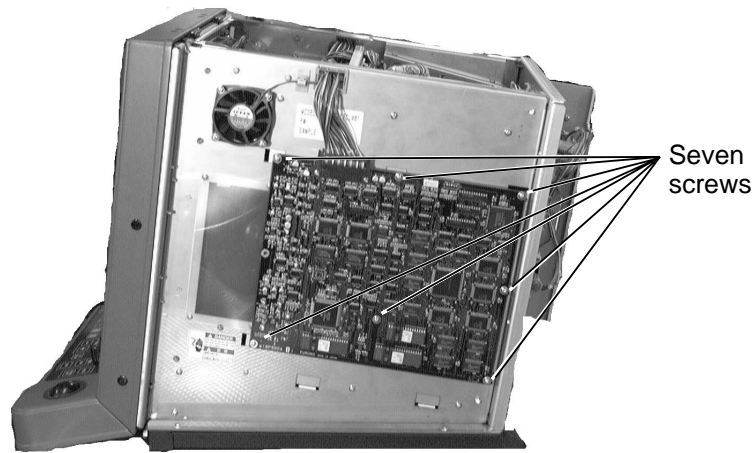

Figure 5-5 Display unit, right side view

3. Connect the cable assy. (supplied) between J107 on the SPU Board and J1 on the ATA Board. Attach toroidal core to cable assy. Fasten cable assy. with cable tie.

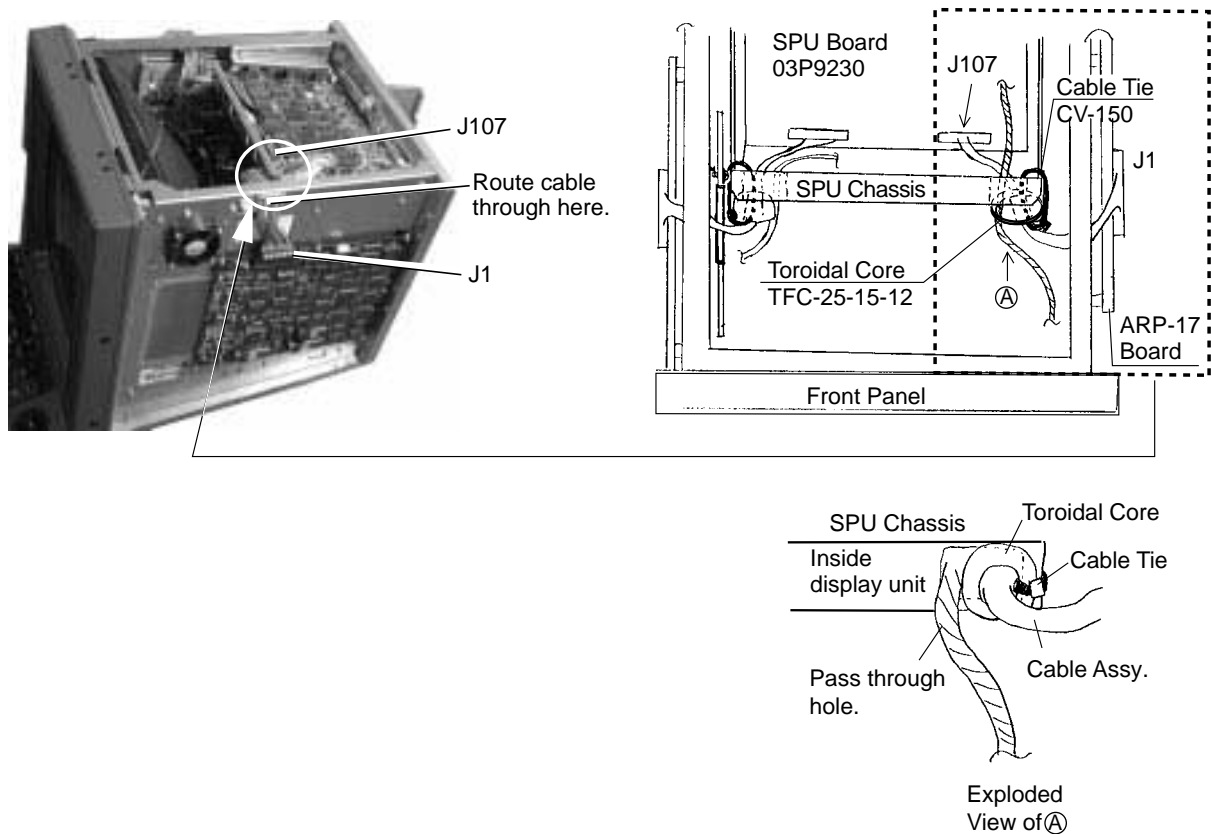

Figure 5-6 Display unit, top view

## Adjustment

1. Set the controls on the radar as follows:

Range: 6 nm  
A/C SEA, A/C RAIN, GAIN: fully counterclockwise

2. Connect a digital multimeter, set to 10 VDC range, to the following points on the ARP Board: (+), TP11 (VS+), (-), TP10 (VS-).

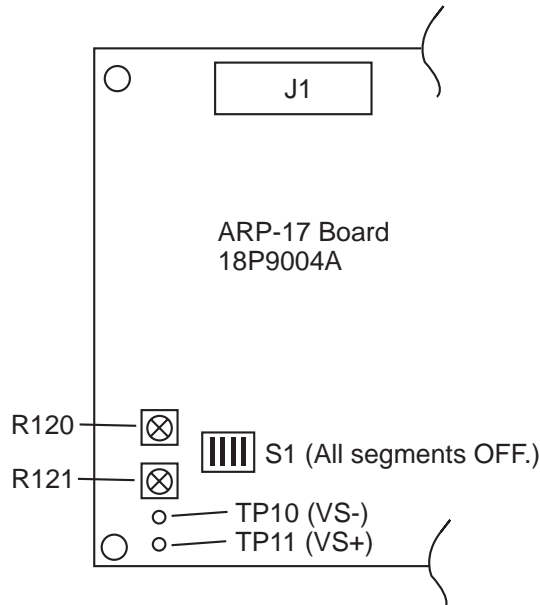

Figure 5-7 ATA Board

3. Adjust potentiometer R121 ("OFFSET") on the ATA Board to show +0.09 to 0.13 V.

4. Set the radar controls and switches as follows:

Range: 24 nm  
A/C SEA, A/C RAIN, GAIN: fully counterclockwise  
Interference rejector: OFF  
Echo stretch: OFF

5. Press [MENU] [0] [0] [0] [0] [6] [6] [0] [0] to display the SET UP 2 menu.

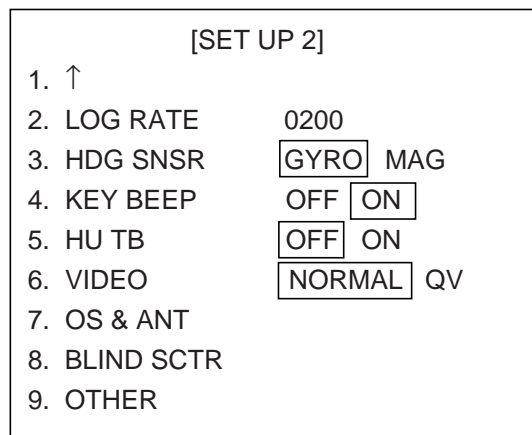

Figure 5-8 SET UP 2 menu

6. Press the [6] key to select QV from the VIDEO field and press the [ENTER/SELECT] key.
7. Adjust potentiometer R120 ("LEVEL") on the ARP Board so that random noise faintly appears.

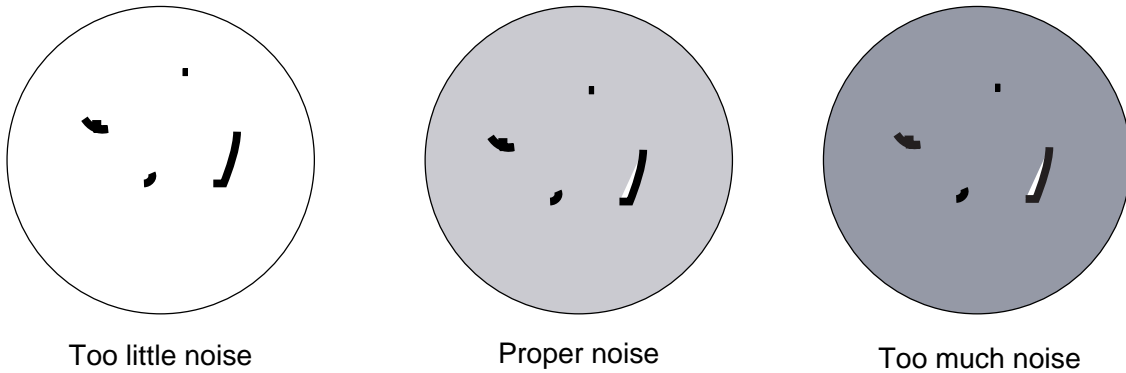

Figure 5-9 How to adjust noise

8. Select NORMAL from the VIDEO field.
9. Press the [ENTER/SELECT] key followed by the [MENU] key.

### Input signal check

Connect speed log and gyrocompass and place the radar in transmit condition. Confirm that all red LEDs, CR1, CR2, CR3, CR7, CR10, CR11 are off, provided that the ship's speed is not zero. If a signal is absent the corresponding LED lights.

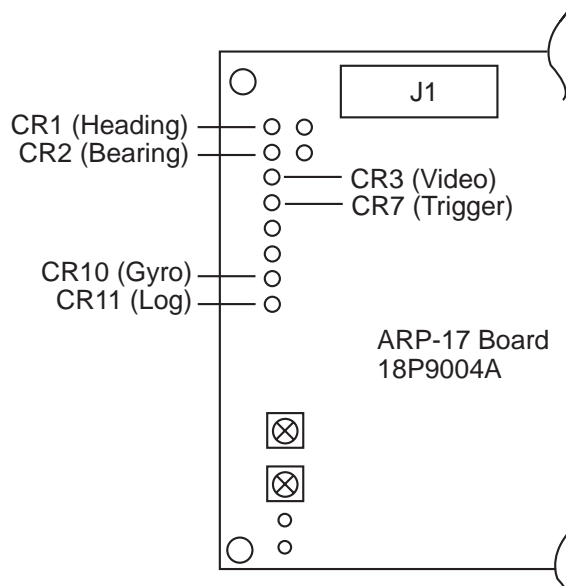
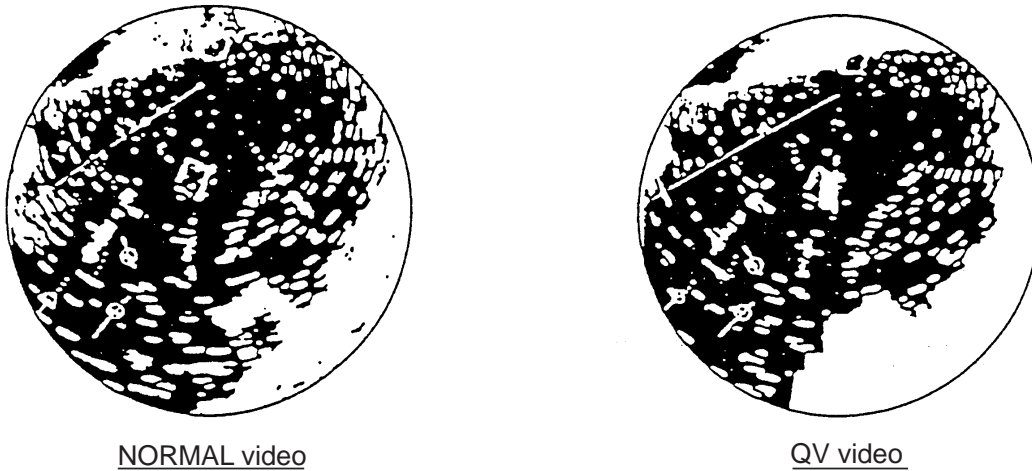

Figure 5-10 ATA Board

## Video signal check

Selecting NORMAL and QV from the SET UP 2 menu, make sure the picture changes as shown in the figure below. If not, adjust R120 and 121 again.



*Figure 5-11 Video signal check*

## Self test

Press [MENU], [0], [0], [0], [0], [2], [2] to run the self test. If NG appears for any ARP-related item, check connections on the ARP Board.

```
FR-1505 SERIES TEST
Program No.      03591511**
ROM Check       OK
RAM Check       OK
Antenna Rotation 24RPM
Tx Trigger Frequency3000Hz
Video Level     000
Video Signal    OK

ARP TEST
1. Program No. 18590411**18590421**
2. ROM Check   OK      OK
3. RAM Check   OK
4. Speed Log   OK 0.0 KT
5. Course      OK
6. Trigger     OK
7. Video Signal OK
8. Bearing Pulse OK
9. Heading Pulse OK
10. Minimum    0003
11. Scan Time  0274
12. Manual Acq. 00
13. Auto Acq.  00
14. FE-Data 1  0000
15. FE-Data 2  0000

Press MENU key to escape.
Press ENTER to check CRT.
```

*Figure 5-12 Self test results*

## 5.3 Video Plotter RP-17

### Necessary parts

*Video plotter installation kit RP-17-17E-2 (Code No. 000-086-989)*

Name	Type	Qty	Code No.
Floppy Disk	NO.03591521XX	1	008-492-790
RP-17 Board	03P9259A	1	008-492-890
Cable Assy.	80-0633	1	008-500-110
Label (plotter)	14-034-8401	1	100-108-100
Label (M-card)	03-134-9106	1	100-235-230
Panhead Screw	M3X8 C2700W	5	000-881-404
Operator's Manual	RP-17-E	1	008-492-840
XH Connector Assy.	03-1796(5P)	1	008-462-830
Toroidal Core	TFC-25-15-12	1	000-129-693
Cable Tie	CV-150	1	000-570-325
Clamp	CK-05H	1	000-570-247
Shrink TubingF(Z)	3X0.25 0.1 m	1	000-105-874

1. Turn off the power and the switch S2 (for AC set) at the rear of the display unit. Turn off all equipment connected to the radar.
2. Unfasten eight screws to detach the cover from the display unit.
3. Fasten the RP Board to the chassis with five screws.
4. Connect the cable assy. (supplied) between J106 on the SPU Board and J4 on the RP Board. Attach toroidal core to cable assy. Fasten cable assy. with cable tie. See the drawing below and at the top of the next page for details.

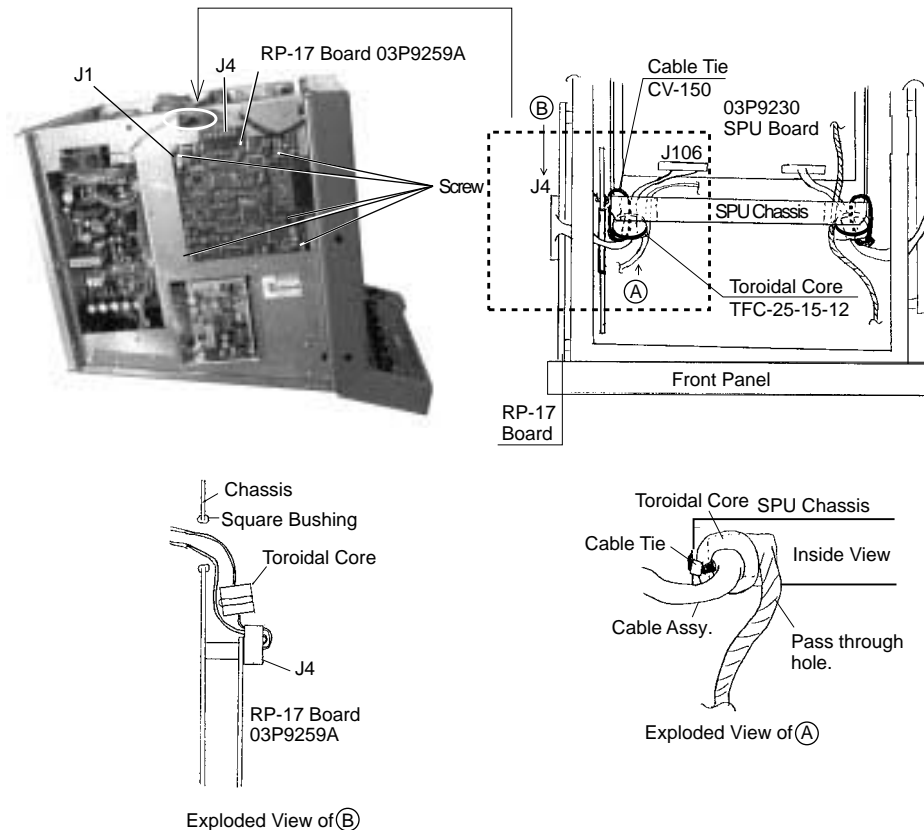

Exploded View of (B)

Figure 5-13 Display unit, left side view



Figure 5-14 Display unit, top view

5. If applicable, connect autopilot to J1 with an XH5P connector. See the figure below for details.

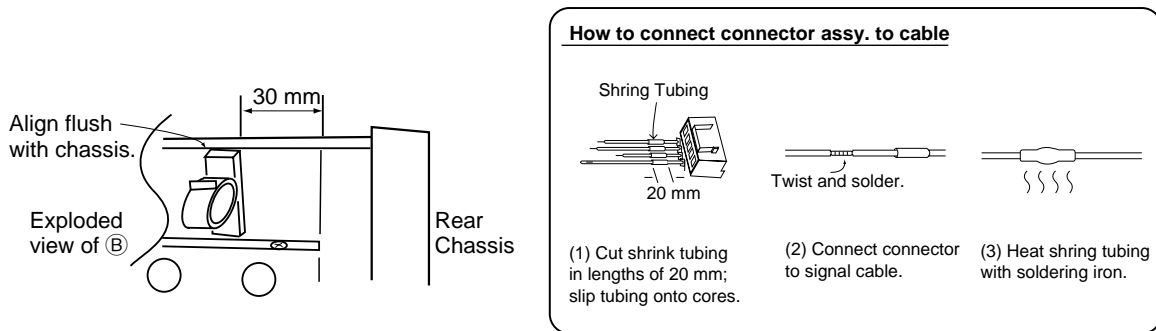
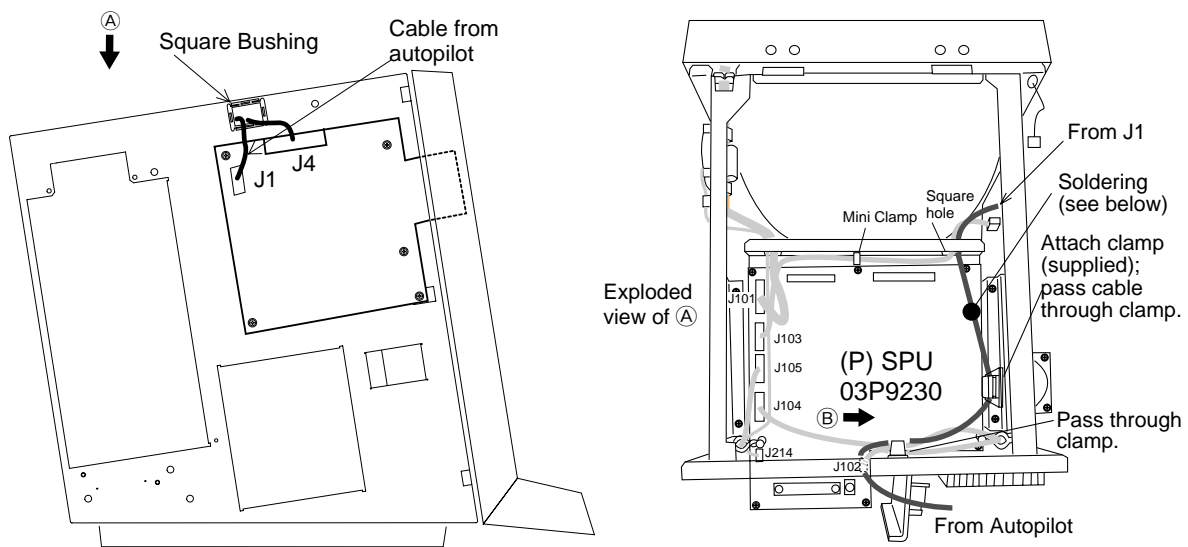
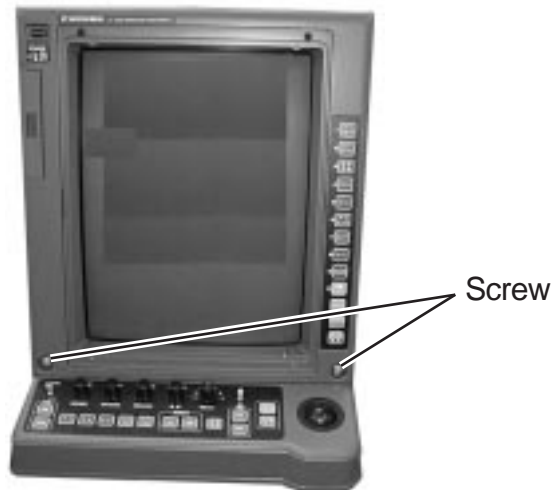

Figure 5-15 Connection of autopilot

6. Close the cover.
7. Referring to the Operator's Manual, conduct the self test. Confirm program number. If the program number is younger than the number recorded on the floppy disk (supplied), the program should be updated. If updating is not required, go to step 19.
8. Loosen the two screws at the front of the display unit and raise the front panel.



*Figure 5-16 Display unit, front view*

9. Dismount the panel on the underside of the control section.



*Figure 5-17 Display unit, front panel raised*

10. Connect a PC to the display unit as shown below. Close the front panel.

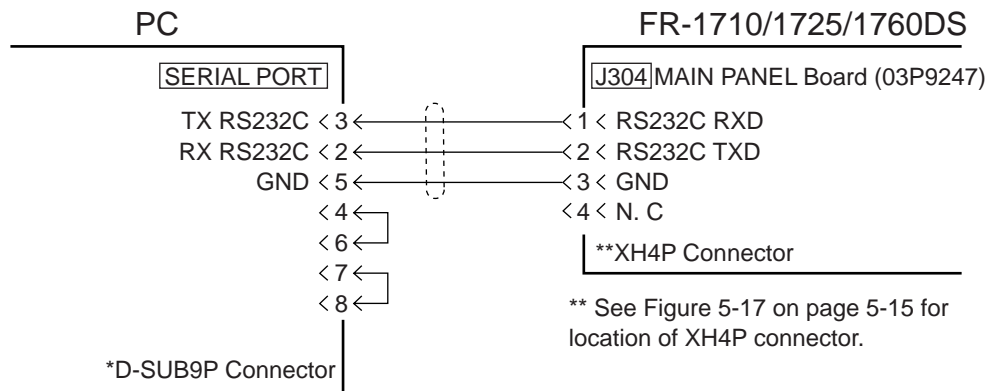

Figure 5-18 Connection of PC to radar display unit

11. Insert program update floppy disk in drive of the PC. Execute the file 1700.bat (for version update). TARGET POWER ON appears on the screen of the PC.

12. Turn on the radar display unit. LOADER RX, MAIN PROG appear successively on the screen of the PC. "Finish Version up. ted" appears on the screen of the PC when the updating has been completed. ("FINISH Ver up" appears on the radar display.) It takes from 5-6 minutes to complete the updating.

13. Disconnect the PC from the radar.

14. Reattach the panel on the underside of the control section.

15. Press and hold down the GAIN control while pressing the power switch.

16. Press the [4] key, and then press the [ENTER/SELECT] key three times.

17. Turn the power off and on. Turn on switch S2 (AC set).

18. Press [MENU], [0], [0], [0], [0], [2], [2] to confirm program version of radar.

19. Attach labels to card slot as below. Turn off the radar.

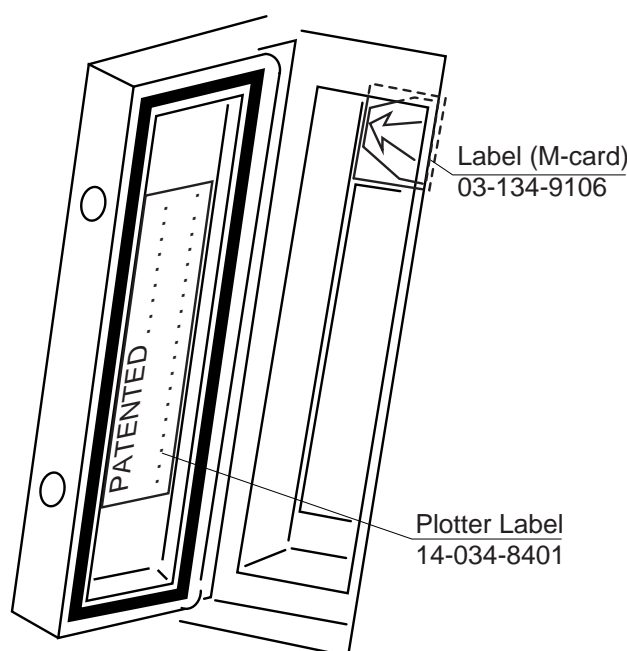

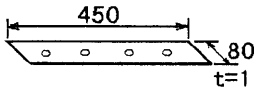
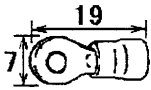
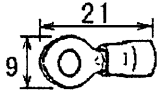
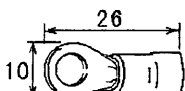
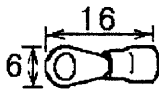

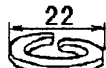
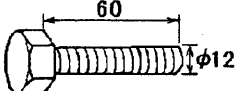

Figure 5-19 Attachment of labels to card slot



**FURUNO**

CODE NO.	008-424-400	03DZ-X-9403 -4 1/2
TYPE	CP03-11603	

工事材料表 INSTALLATION MATERIALS					
番号 NO.	名称 NAME	略図 OUTLINE	型名/規格 DESCRIPTIONS	数量 Q'TY	用途/備考 REMARKS
1	シールワッシャー SEAL WASHER		03-001-3002-0	4	
			CODE NO. 300-130-020		
2	防蝕ゴム CORROSION-PROOF RUBBER MAT		03-029-0301-2	2	
			CODE NO. 100-091-112		
3	圧着端子 CRIMP-ON LUG		FV1.25-M3 7カ	26	
			CODE NO. 000-538-110		
4	圧着端子 CRIMP-ON LUG		FV2-4 7カ	16	
			CODE NO. 000-538-118		
5	圧着端子 CRIMP-ON LUG		FV5.5-4	1	
			CODE NO. 000-538-123		
6	圧着端子 CRIMP-ON LUG		FVD1.25-3	2	
			CODE NO. 000-116-634		
7	六角ナット 1種 HEX. NUT		M12 SUS304	4	
			CODE NO. 000-863-112		
8	ミガキ平座金 FLAT WASHER		M12 SUS304	4	
			CODE NO. 000-864-132		
9	バネ座金 SPRING WASHER		M12 SUS304	4	
			CODE NO. 000-864-263		
10	六角ボルト (全ネジ) HEX. BOLT		M12X60 SUS304	4	
			CODE NO. 000-862-191		

DWG NO.



C3357-M03- E

FURUNO ELECTRIC CO., LTD.

(略図の寸法は、参考値です。 DIMENSIONS IN DRAWING FOR REFERENCE ONLY.)

**FURUNO**

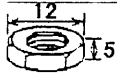
CODE NO.	008-424-400	03DZ-X-9403 -4
TYPE	CP03-11603	2/2

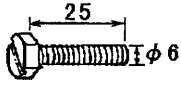
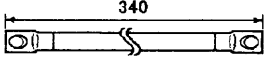
工事材料表 INSTALLATION MATERIALS					
番号 NO.	名称 NAME	略図 OUTLINE	型名/規格 DESCRIPTIONS	数量 Q'TY	用途/備考 REMARKS
11	六角ナット 1種 HEX. NUT		M6 SUS304	1	
			CODE NO. 000-863-109		
12	六角平座金 FLAT WASHER		M6 SUS304	3	
			CODE NO. 000-864-129		
13	六角座金 SPRING WASHER		M6 SUS304	1	
			CODE NO. 000-864-260		
14	六角ボルト HEX. BOLT		M6X25 SUS304	1	
			CODE NO. 000-862-180		
15	アース線 GROUNDING WIRE		RW-4747-1 03S4747	1	
			CODE NO. 000-566-000		

DWG NO.  
C3357-M04- E

FURUNO ELECTRIC CO., LTD.

(略図の寸法は、参考値です。 DIMENSIONS IN DRAWING FOR REFERENCE ONLY.)

**FURUNO**

CODE NO.	008-490-610	03FU-X-9402 -1 1/1
TYPE	CP03-19404	

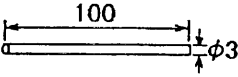
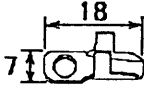
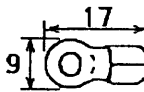
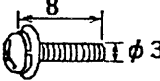
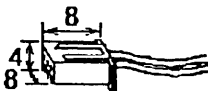
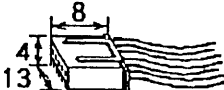
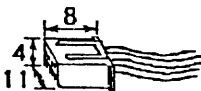
工事材料表 INSTALLATION MATERIALS		FR-1760DS 船舶用レーダー MARINE RADAR			
番号 NO.	名称 NAME	略図 OUTLINE	型名/規格 DESCRIPTIONS	数量 Q'TY	用途/備考 REMARKS
1	スミューブ F(Z) HEAT-SHRINK TUBE		3X0.25 加 *0.10M*	2	
			CODE NO. 000-105-874		
2	特殊カ LUG		7x4x4 ス	2	
			CODE NO. 000-536-100		
3	圧着端子 CRIMP-ON LUG		8NK4	4	
			CODE NO. 000-538-180		
4	ナハセムスネジ B WASHER HEAD SCREW		M3X8 C2700 MBN12	2	
			CODE NO. 000-881-404		
5	XHコネクタ XH CONNECTOR		03-1768(3P)	1	
			CODE NO. 008-459-090		
6	XHコネクタ XH CONNECTOR		03-1796(5P)	4	
			CODE NO. 008-462-830		
7	XHコネクタ XH CONNECTOR		03-1798(4P)	1	
			CODE NO. 008-463-400		

DWG NO.

C3456-M01-B

FURUNO ELECTRIC CO., LTD

(略図の寸法は、参考値です。 DIMENSIONS IN DRAWING FOR REFERENCE ONLY.)

# FURUNO

CODE NO.	008-424-390	03DZ-X-9402 -1 1/1
TYPE	CP03-11602	

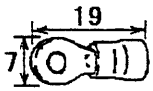
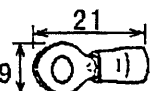
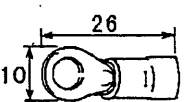

工事材料表 INSTALLATION MATERIALS		FR-1460DS 船舶用レダ- FR-1760DS MARINE RADAR 空中線電源部用 FOR SCANNER POWER SUPPLY			
番号 NO.	名称 NAME	略図 OUTLINE	型名/規格 DESCRIPTIONS	数量 Q'TY	用途/備考 REMARKS
1	圧着端子 CRIMP-ON LUG		FV1.25-M3 7カ	9	
			CODE NO. 000-538-110		
2	圧着端子 CRIMP-ON LUG		FV2-4A 7カ	13	
			CODE NO. 000-538-118		
3	圧着端子 CRIMP-ON LUG		FV5.5-4	6	
			CODE NO. 000-538-123		

DWG NO. C3357-M02- C

FURUNO ELECTRIC CO., LTD.

(略図の寸法は、参考値です。 DIMENSIONS IN DRAWING FOR REFERENCE ONLY.)

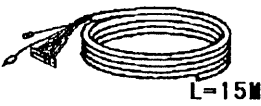
# FURUNO

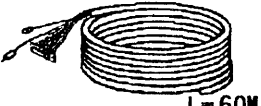





工事材料表 INSTALLATION MATERIALS		FR-1760DS 船舶用レーダー MARINE RADAR		CODE NO.	03FU-X-9404 -0
				TYPE	1/1
番号 NO.	名称 NAME	略図 OUTLINE	型名/規格 DESCRIPTIONS	数量 Q'TY	用途/備考 REMARKS
1	信号ケーブル SIGNAL CABLE	 L=15M	S03-78-15	1	選択 TO BE SELECTED
			CODE NO.		
2	信号ケーブル SIGNAL CABLE	 L=20M	S03-78-20	1	選択 TO BE SELECTED
			CODE NO.		
3	信号ケーブル SIGNAL CABLE	 L=30M	S03-78-30	1	選択 TO BE SELECTED
			CODE NO.		
4	信号ケーブル組品 SIGNAL CABLE ASSY.	 L=60M	S03-78-60	1	選択 TO BE SELECTED
			CODE NO.		

DWG NO. C3456-M02- A

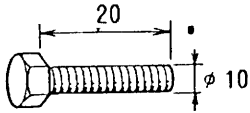
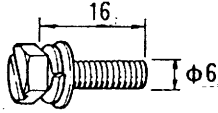
FURUNO ELECTRIC CO., LTD

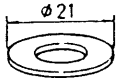
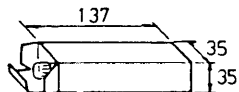
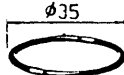
(略図の寸法は、参考値です。 DIMENSIONS IN DRAWING FOR REFERENCE ONLY.)

**FURUNO**

工事材料表 INSTALLATION MATERIALS		レーダー空中線部組立材料 RADAR ANTENNA ASSEMBLING MATERIALS			
番号 No.	名称 NAME	略図 OUTLINE	型名 / 規格 DESCRIPTIONS	数量 Q'TY	用途 / 備考 REMARKS
1	六角ボルト HEX. BOLT		M10X20 SUS304	8	
			CODE No. 000-862-158		
2	六角セムスB(スリ割付) HEX. BOLT (SLOTTED, WASHER HEAD)		M6X16 SUS304	8	
			CODE No. 000-882-061		
3	バネ座金 SPRING WASHER		M10 SUS304	8	
			CODE No. 000-864-261		
4	ミガキ平座金 FLAT WASHER		M10 SUS304	8	
			CODE No. 000-864-131		
5	スパーズリーボンド ADHESIVE		1211 50g	1	
			CODE No. 000-854-118		
6	O-RING		WP-20	2	
			1115-70		
			CODE No.		
			CODE No.		
			CODE No.		
			CODE No.		
				図番 DWG. No. C3291-013-A	1/1
				検図 CHECKED	  

**FURUNO**

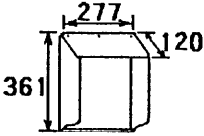
付属品表		FR-1710/1725/1760DS 船舶用レーダ		CODE NO.	008-489-860	03FU-X-9501 -0 1/1
ACCESSORIES		MARINE RADAR		TYPE	FP03-06521	
番号 NO.	名称 NAME	略図 OUTLINE	型名/規格 DESCRIPTIONS	数量 Q'TY	用途/備考 REMARKS	
1	ホールの栓 HOLE PLUG		DP-687 栓	2		
			CODE NO.			
2	フード組品 HOOD ASSY.		FP03-06523	1		
			CODE NO.			

DWG NO.

C3453-F01-A

FURUNO ELECTRIC CO., LTD

(略図の寸法は、参考値です。 DIMENSIONS IN DRAWING FOR REFERENCE ONLY.)

**FURUNO**

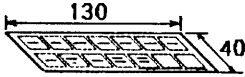
付属品表 ACCESSORIES		FR-1760DS 船舶用レーダー MARINE RADAR		CODE NO.	008-490-620	03FU-X-9502 -0
				TYPE	FP03-06522	1/1
番号 NO.	名称 NAME	略図 OUTLINE	型名/規格 DESCRIPTIONS	数量 Q'TY	用途/備考 REMARKS	
1	ユーザーシート(E) USER KEYSHEET(E)		03-143-1611-0 CODE NO. 100-265-950	1		

DWG NO.

C3456-F01-A

FURUNO ELECTRIC CO., LTD

(略図の寸法は、参考値です。 DIMENSIONS IN DRAWING FOR REFERENCE ONLY.)



# FURUNO

CODE NO.	008-489-890	03FU-X-9302 -1
TYPE	SPO3-12701	BOX NO. P

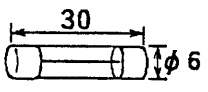
SHIP NO.		SPARE PARTS LIST FOR		U S E			SETS PER VESSEL
		FR-1760DS 船舶用レーダー RHRS-2005RC  MARINE RADAR		指示部  FOR DISPLAY UNIT			
ITEM NO.	NAME OF PART	OUTLINE	DWG. NO. OR TYPE NO.	QUANTITY			REMARKS/CODE NO.
				WORKING		SPARE	
PER SET	PER VES						
1	ヒューズ FUSE		FG80 20A AC125V	1		2	
							000-549-015
MFR'S NAME		FURUNO ELECTRIC CO., LTD.		DWG NO.	C3456-P01- B		1/1

(略図の寸法は、参考値です。 DIMENSIONS IN DRAWING FOR REFERENCE ONLY.)

# FURUNO

CODE NO.	008-424-380	03DZ-X-9303 -6
TYPE	SP03-09203	BOX NO. P

SHIP NO.		SPARE PARTS LIST FOR		U S E			SETS PER VESSEL
		FR-1430DS/1460DS 船舶用レーダー FR-1760DS FR-2155/2155-B FR/FAR-2855 MARINE RADAR					
ITEM NO.	NAME OF PART	OUTLINE	DWG. NO. OR TYPE NO.	QUANTITY			REMARKS/CODE NO.
				WORKING		SPARE	
				PER SET	PER VES		
1	カーボンブラシ CARBON BRUSH		T-A01297B	4		4	000-115-023
MFR'S NAME	FURUNO ELECTRIC CO., LTD			DWG NO.	C3357-P03- H		1/1

(略図の寸法は、参考値です。 DIMENSIONS IN DRAWING FOR REFERENCE ONLY.)

# FURUNO

CODE NO.	008-424-370	03DZ-X-9302 -8
TYPE	SP03-09202	BOX NO. P

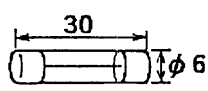
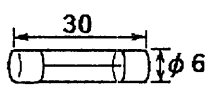
SHIP NO.		SPARE PARTS LIST FOR		U S E			SETS PER VESSEL
ITEM NO.	NAME OF PART	OUTLINE	DWG. NO. OR TYPE NO.	QUANTITY		REMARKS/CODE NO.	
				WORKING			
				PER SET	PER VES		SPARE
1	ヒューズ FUSE		FGBO-A 2A AC125V	2		4 000-549-062	
2	ヒューズ FUSE		FGBO-A 5A AC125V	1		2 000-549-064	
MFR'S NAME		FURUNO ELECTRIC CO.,LTD		DWG NO.	C3357-P02- J		1/1

(略図の寸法は、参考値です。 DIMENSIONS IN DRAWING FOR REFERENCE ONLY.)

範囲 DIMENSION	公差 TOL.
$L \leq 50$	$\pm 1 \text{ mm}$
$50 < L \leq 100$	$\pm 2 \text{ mm}$
$100 < L \leq 500$	$\pm 3 \text{ mm}$
$500 < L \leq 1000$	$\pm 4 \text{ mm}$

表1 TABLE 1

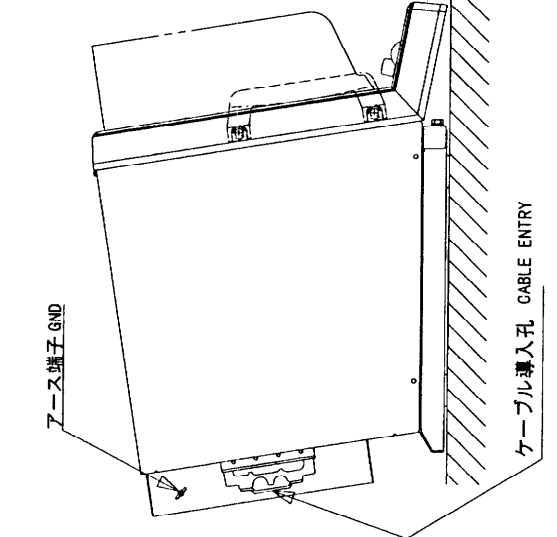
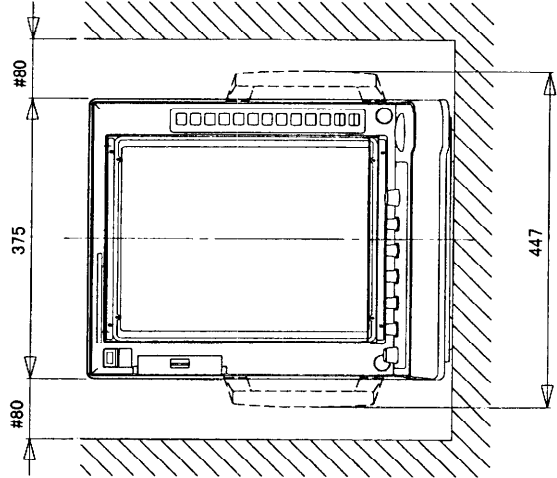
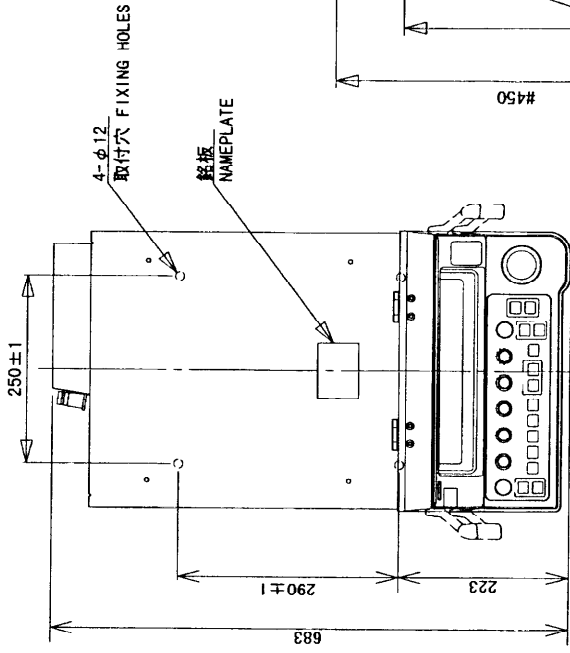

注記 1) 装備ケーブルはサービス時、指示部を前方に充分引き出せるよう余裕を持たせること。  
 2) 取付用ネジはM10ボルトまたはコーチボルト呼び径9を使用のこと。  
 3) #印寸法は最小サービス空間寸法とする。  
 4) 指定外の寸法公差は表1による。

NOTE 1. KEEP ENOUGH CABLE LENGTH BEHIND DISPLAY.  
 2. USE M10 BOLTS OR φ9 COACH SCREWS FOR FIXING THE UNIT.  
 3. #. RECOMMENDED SERVICE CLEARANCE  
 4. TABLE 1 INDICATES TOLERANCE OF DIMENSIONS.

DRAWN Aug 14 88 N. NAKAMURA	TITLE ROP-120
CHECKED Apr 22 88 K. Kawano	名称 指示部
APPROVED Apr 22 88 K. Kawano	外寸図
SCALE 1/10	NAME DISPLAY UNIT
MASS 38 kg	OUTLINE DRAWING
DWG No. C3453-G01-A	

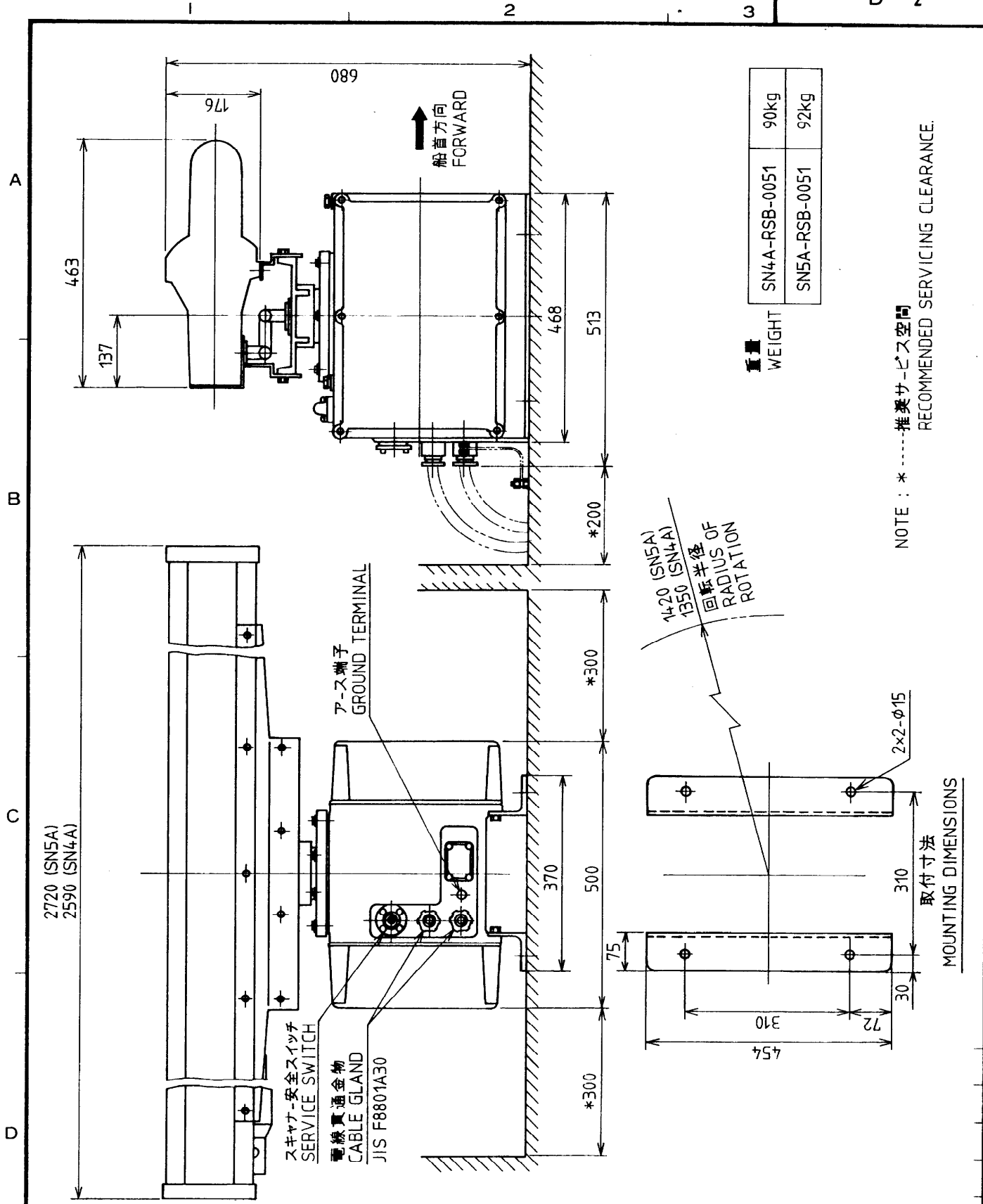

承認 APPROVED	品番 ITEM	品名 NAME	材質 MATERIAL	数量 Q'TY	図番 DWG. NO.	摘要 REMARKS
JUN. 28 '91 T. NAKANO		三角法 THIRD ANGLE PROJECTION				
検図 CHECKED	JUN. 28 '91 N. SAITE	尺度 SCALE		1 / 10		名称 TITLE
製図 DRAWN	JUN. 28 '91 I. AMANO	重量 WEIGHT	kg		図番 DWG. NO.	SN4A/5A-RSB-0051 レーダ-空中線部外寸図 RADAR SCANNER UNIT
					C3357-G01-B	

表 1 TABLE 1

寸法区分 (mm) DIMENSION	公差 (mm) TOLERANCE
$0 < L \leq 50$	$\pm 1.5$
$50 < L \leq 100$	$\pm 2.5$
$100 < L \leq 500$	$\pm 3$

A  
B  
C  
D

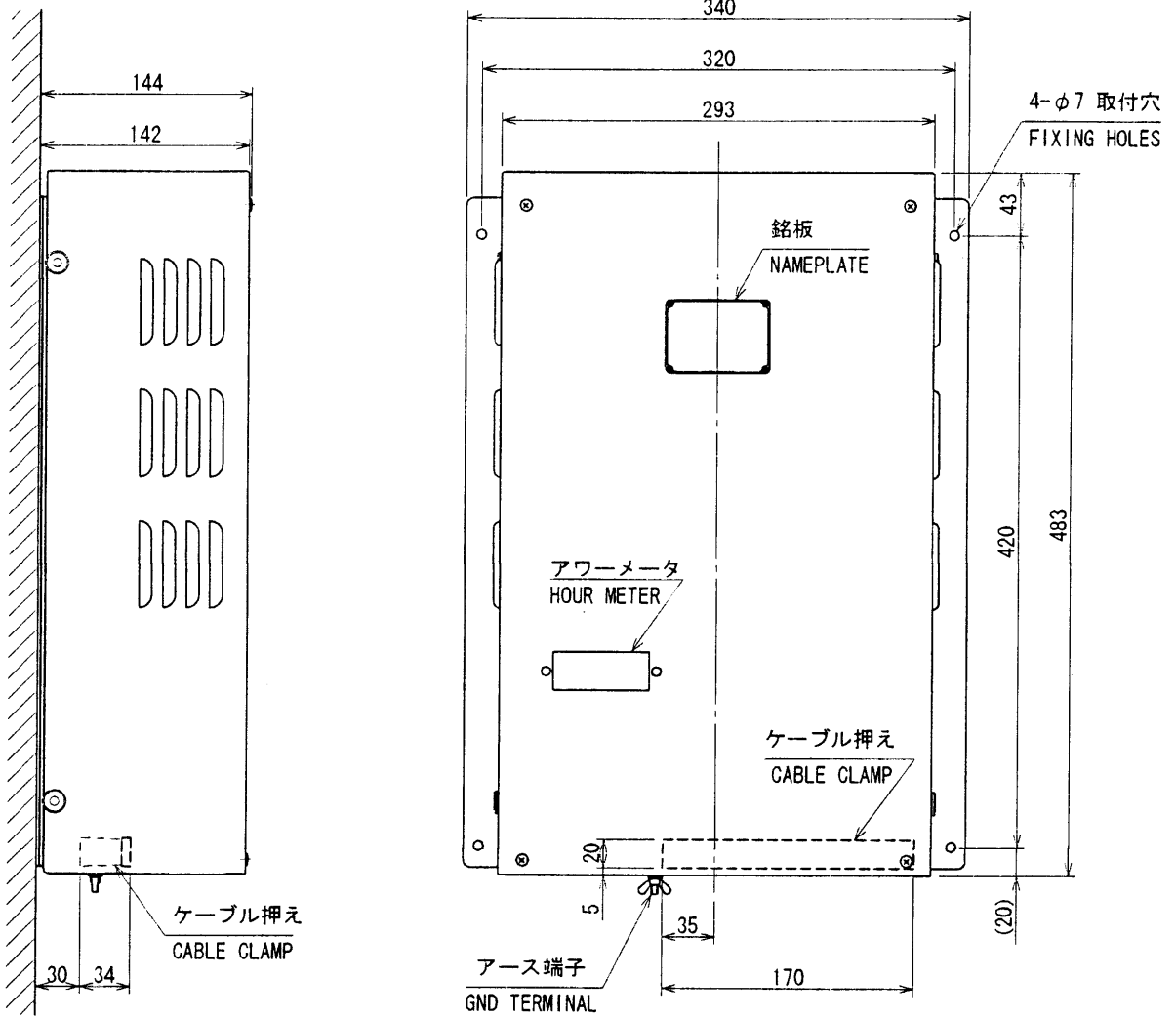

注記

1) 指定なき寸法公差は表 1 による。

NOTE

1. TABLE 1 INDICATES TOLERANCE OF DIMENSIONS.

DRAWN Aug 24 '00 T. YAMASAKI	TITLE PSU-001/002
CHECKED Aug 24 '00 T. YAMASAKI	名称 空中線電源部
APPROVED Aug 24 '00 T. YAMASAKI	外寸図
SCALE 1/5	NAME POWER SUPPLY UNIT
MASS 7 ±10% kg	
DWG. No. C3353-G01-E	03-102-700G-1 OUTLINE DRAWING

# FURUNO

D-4

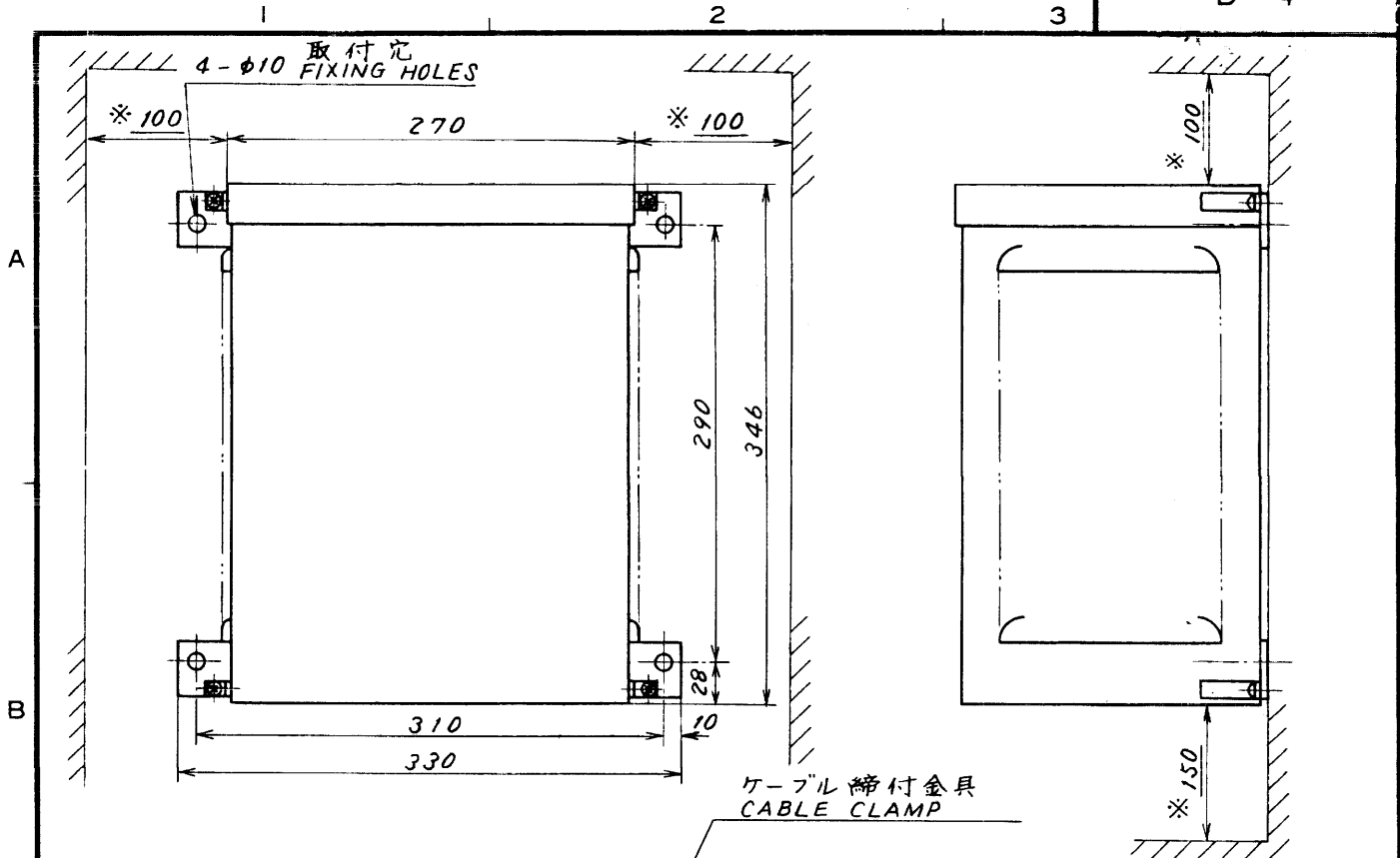

※: 最小サービス空間  
MIN. SERVICING CLEARANCE

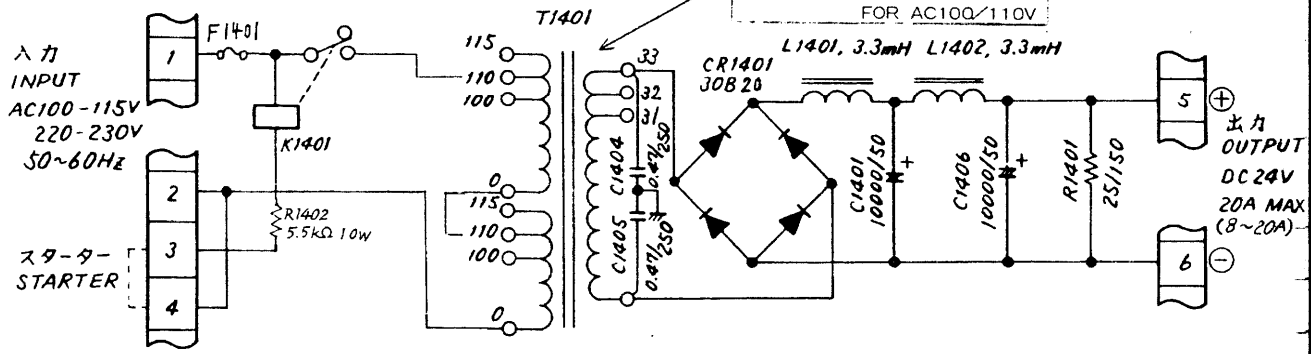
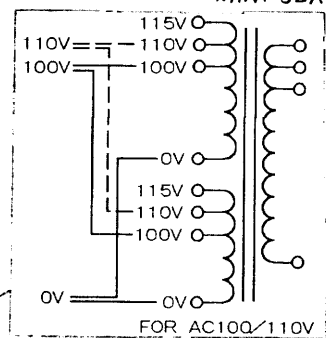

注記 AC100V入力に対してはT1401の一次巻線の接続を変更し、  
リレー抵抗R1402の両端をジャンパーで短絡する。  
NOTE: FOR 100VAC INPUT, CHANGE T1401 PRIMARY WINDINGS CONNECTIONS  
AND PUT JUMPER ACROSS R1402.

DRAWN <i>Apr 11 '97</i> <i>T. YAMASAKI</i>				TYPE	RU-3424
CHECKED <i>Apr. 17 '97</i> <i>K. Kusunoki</i>				名称	整流器
APPROVED					外寸図
SCALE	MASS	APPLICABLE TO;	BLOCK NO.	NAME	RECTIFIER UNIT
<i>1/5</i>	<i>25 kg</i>	(MODEL)			OUTLINE DRAWING
DWG NO. <i>C3002-004-H</i>					

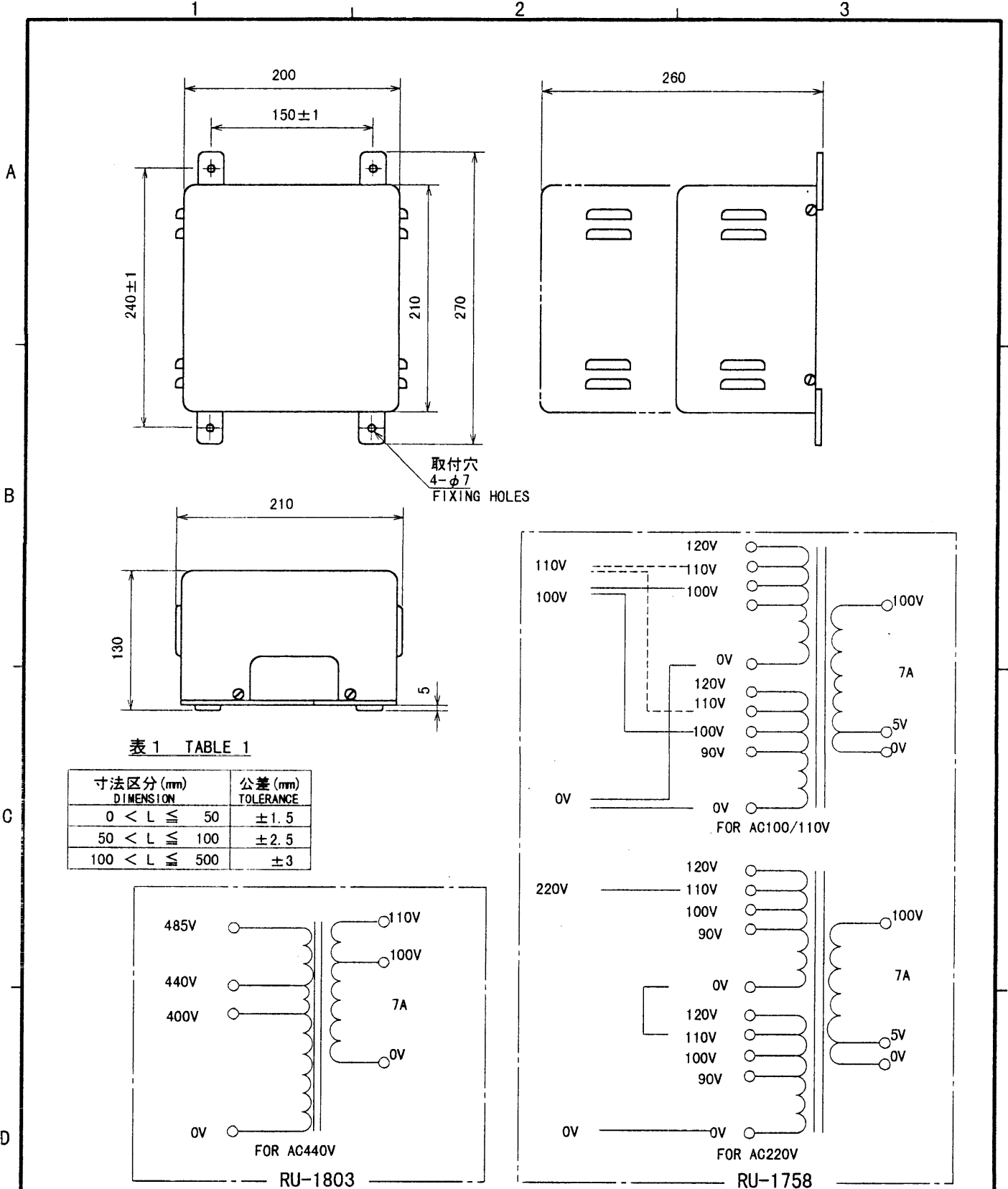

注記

1) 指定なき寸法公差は表1による。

NOTE

1. TABLE 1 INDICATES TOLERANCE OF DIMENSIONS.

DRAWN <i>June 28 '00 T. YAMASAKI</i>		TITLE RU-1758/1803	
CHECKED <i>June 28 '00 Y. Kim</i>		名称 トランスユニット	
APPROVED <i>June 28 '00 Y. Kim</i>		外寸図	
SCALE 1/5	MASS 12 kg ±10%	NAME TRANSFORMER UNIT	
DWG. No. C3003-001-E		OUTLINE DRAWING	



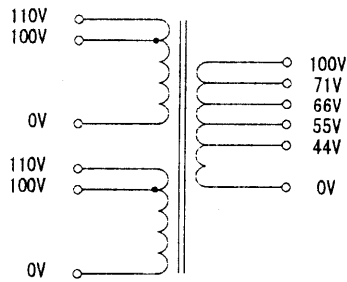
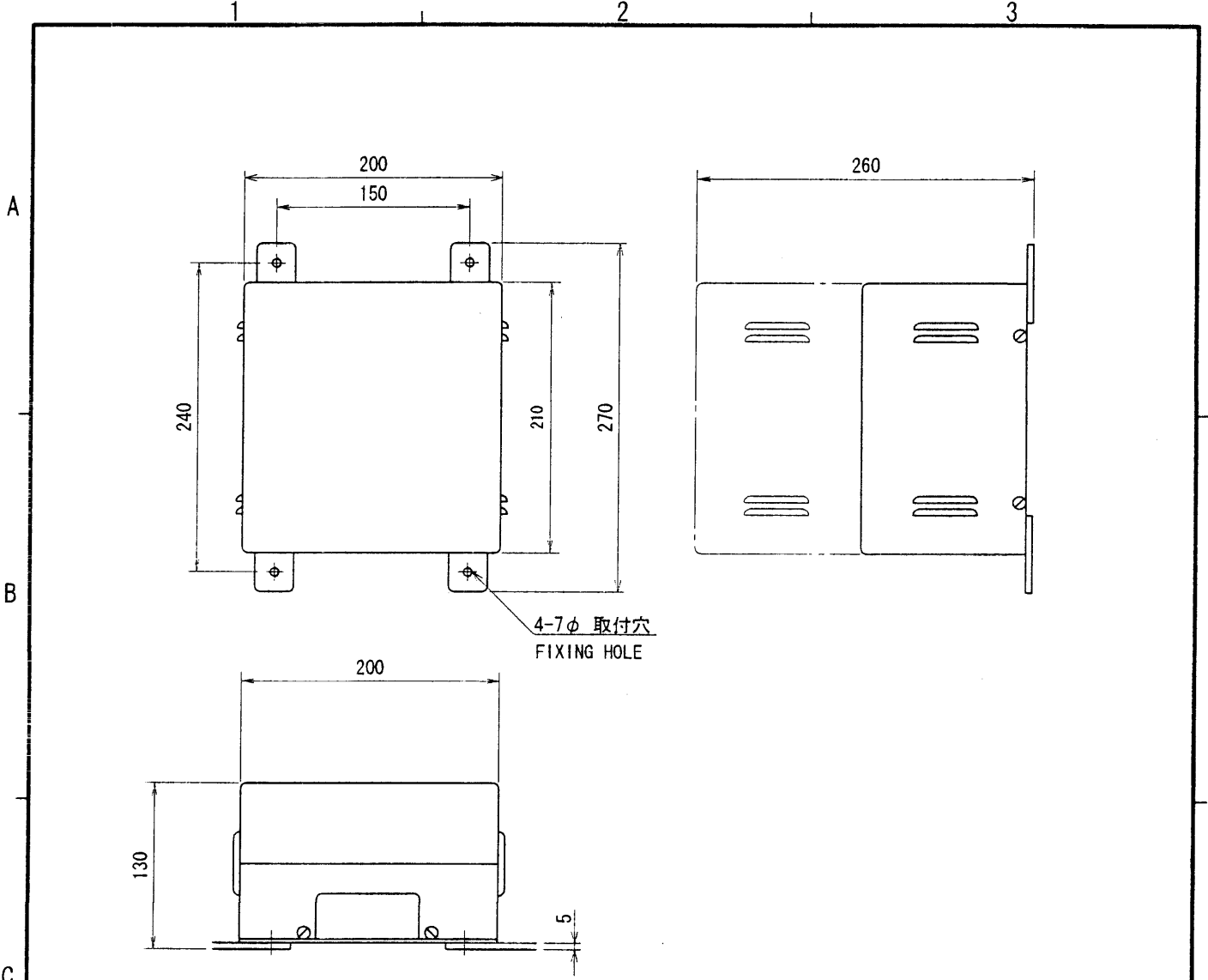

コンパス安全距離 COMPASS SAFE DISTANCE

スタンダード STANDARD	2.1 m
ステアリング STEERING	1.5 m

DRAWN <i>Apr 16 '00 T. YAMASAKI</i>	TITLE RU-3305
CHECKED <i>Apr 17 '00 Y. Kuni</i>	名称 トランスユニット
APPROVED <i>Apr 17 '00 T. Kuni</i>	外寸図
SCALE 1/5	NAME TRANSUFORMER UNIT
MASS ±10% 12.2 kg	OUTLINE DRAWING
DWG. No. C3003-004- D	

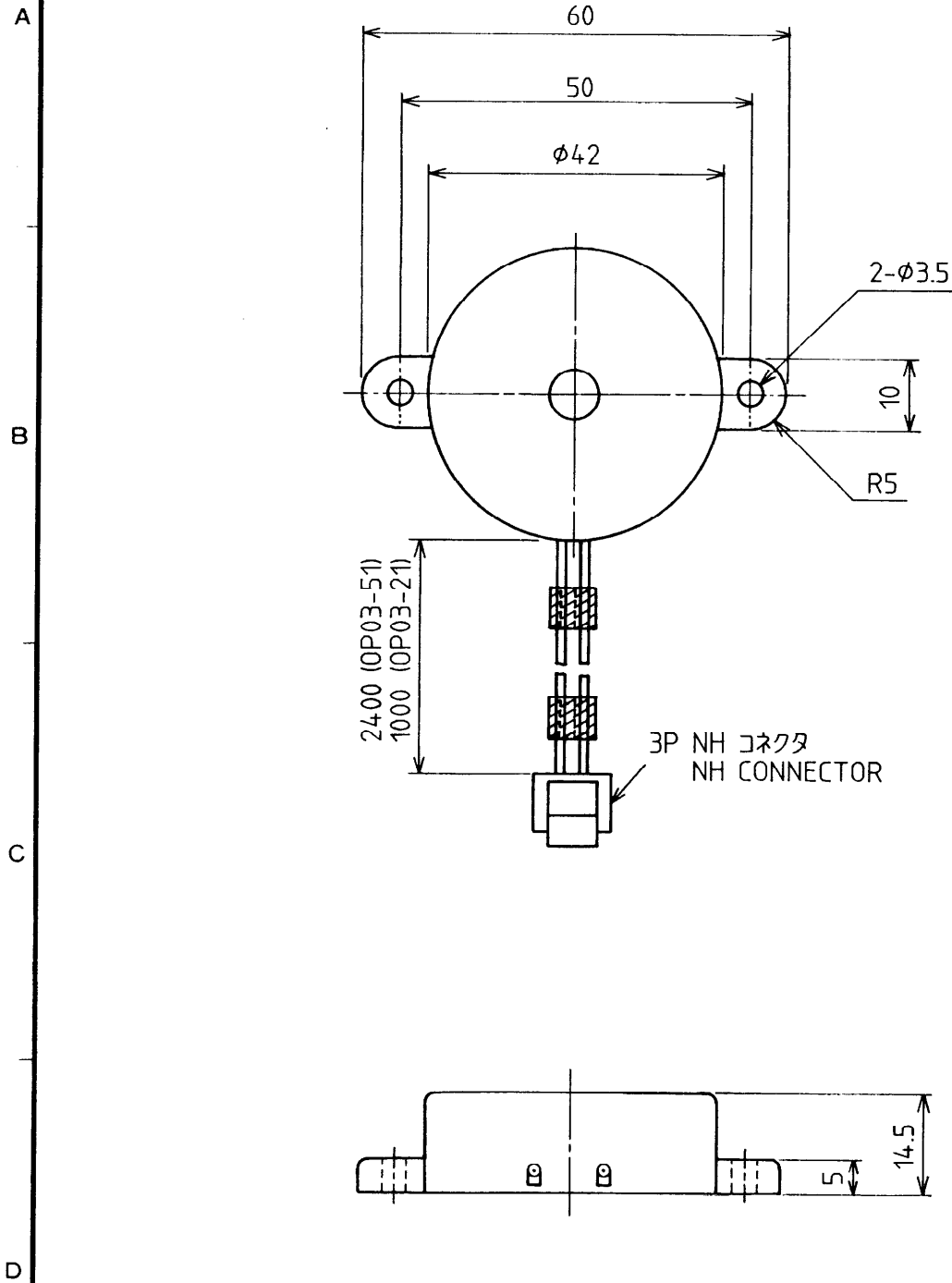

品番 ITEM	品名 NAME	材質 MATERIAL	数量 Q'TY	図番 DWG.NO.	摘要 REMARKS
承認 APPROVED	三角法 THIRD ANGLE PROJECTION	名称 TITLE			
検 CHECKED	尺度 SCALE	OP03-21 外付ブザー OP03-51 EXTERNAL BUZZER			
製 DRAWN	重量 WEIGHT	kg	図番 DWG.NO.	C5094-008-B	

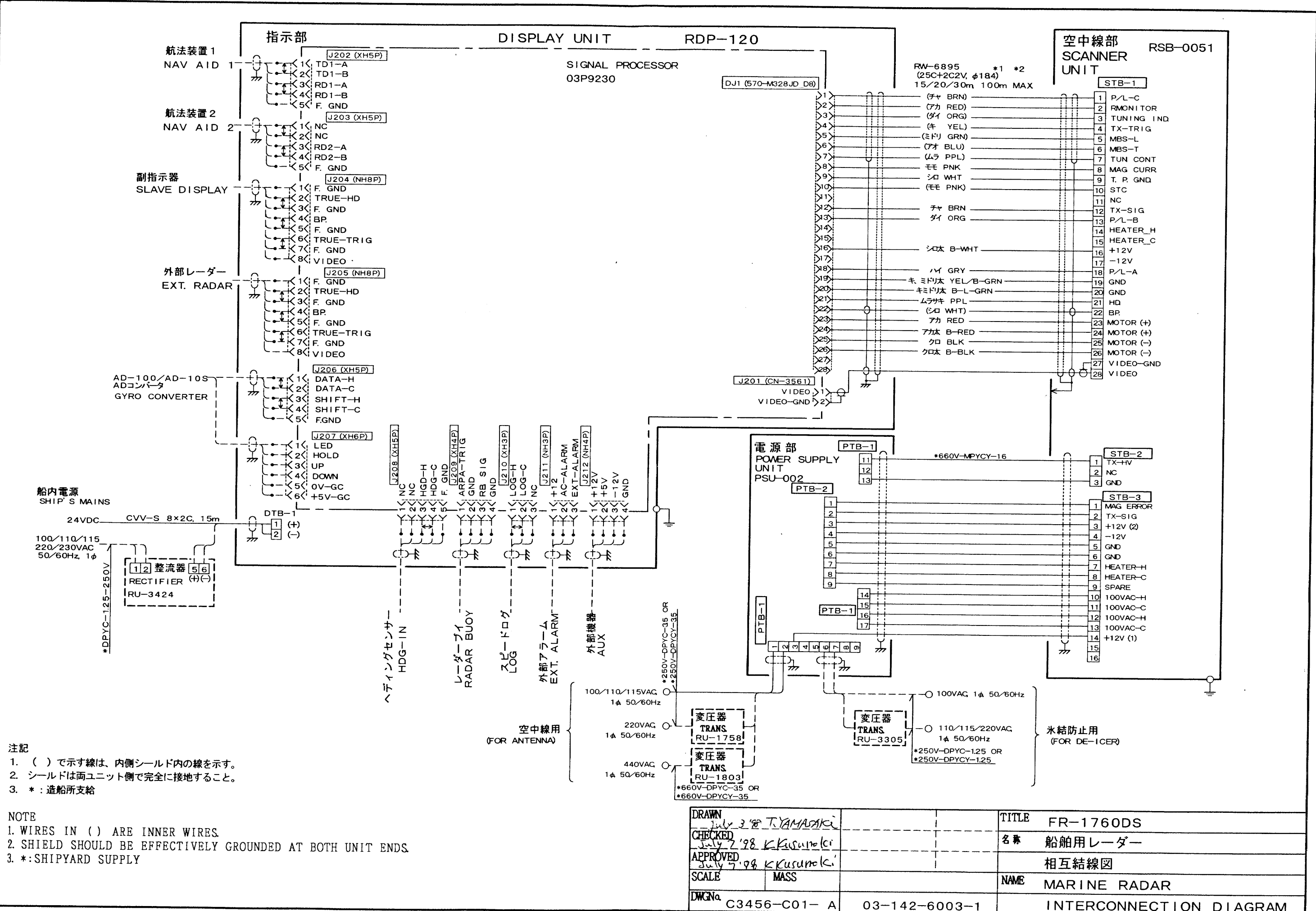

DRAWN July 2 '98 T. YAMASAKI	TITLE FR-1760DS
CHECKED July 7 '98 K. Kusumaki	名称 船舶用レーダー
APPROVED July 7 '98 K. Kusumaki	相互結線図
SCALE MASS	NAME MARINE RADAR
DWG No. C3456-C01-A	INTERCONNECTION DIAGRAM

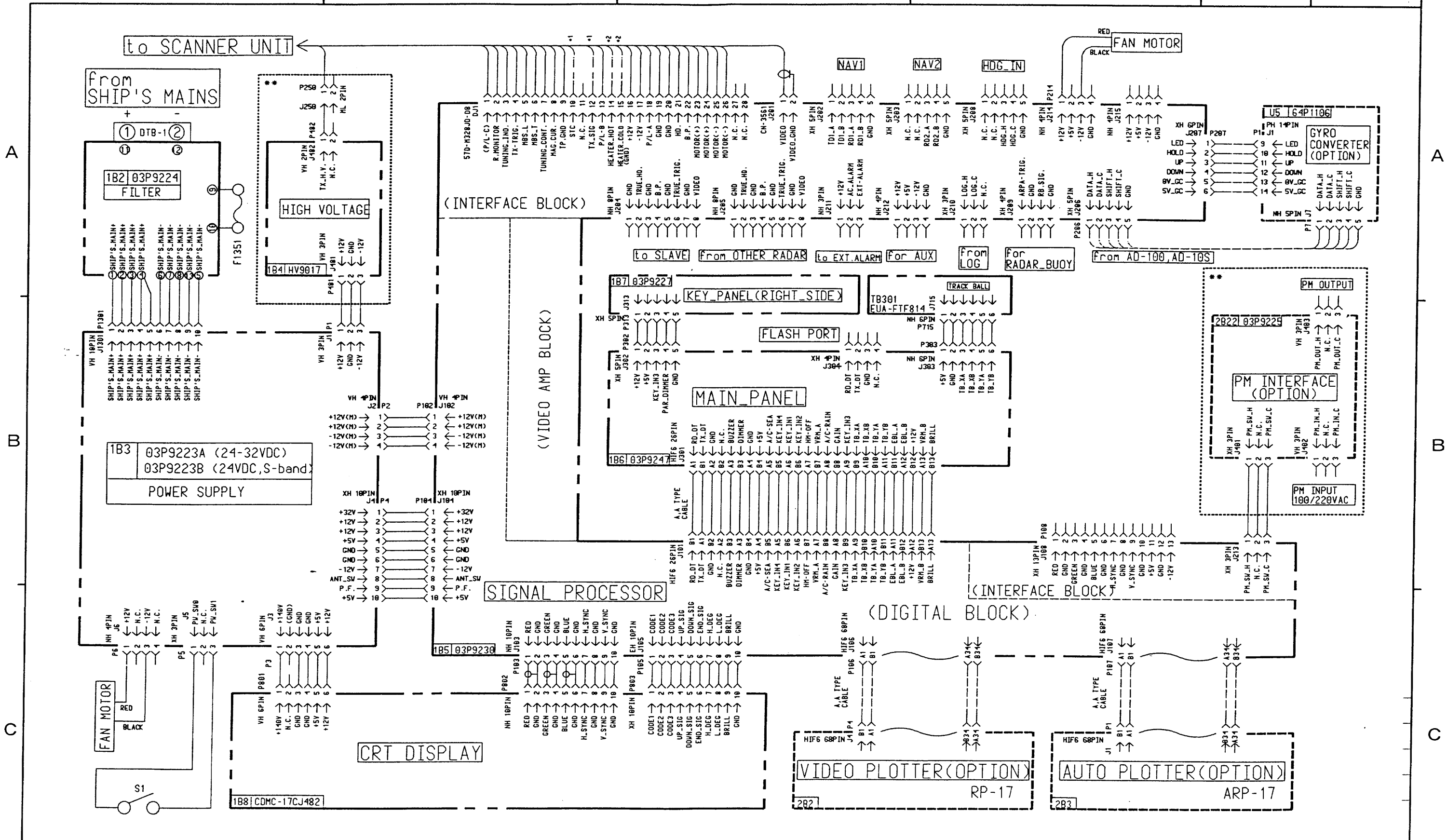

\*1:connect at FR-1760DS  
 \*2:connect at FR-1710/1725  
 \*\*:only FR-1710/1725

DRAWN May 28 '99 T. YAMASAKI	TYPE RDP-120
CHECKED May 31 '99 K. Kusuwaki	名称 指示部 (DC)
APPROVED May 31 '99 K. Kusuwaki	回路図
SCALE MASS kg	NAME DISPLAY UNIT (DC)
DWG NO. C3453-K01-C	APPLICABLE TO; (MODEL)
	BLOCK NO. 03-143-6004-5
	SCHMATIC DIAGRAM

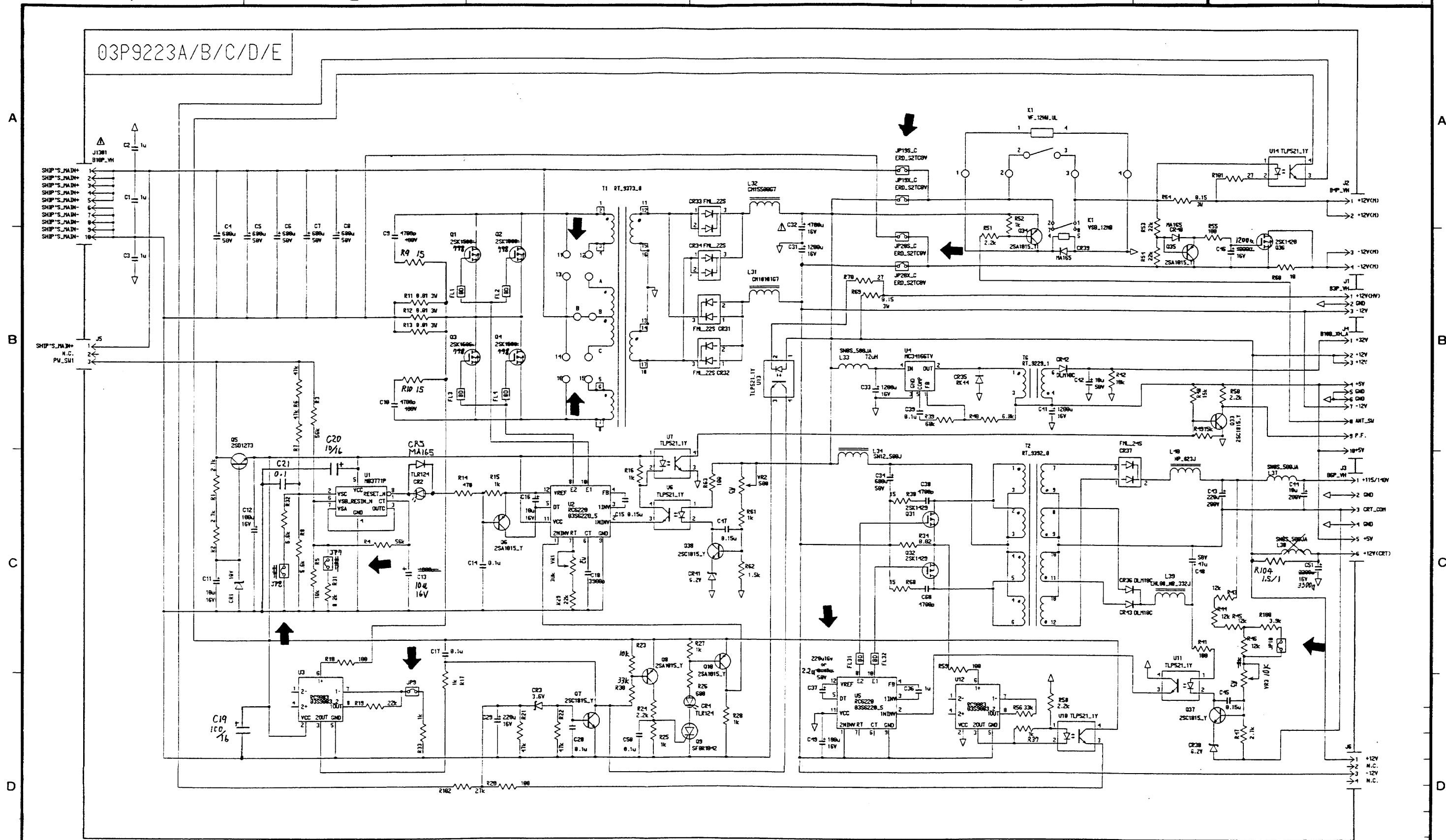

MODEL	SHIP'S MAIN	P.C.B.	JP7	JP8	JP9	11.A	12	13	14	15	15.C	16	JP19	JP20	K1	C37	JP10
FR_1710/25	DC24.32V	03P9223A	○	○	○	×	×	×	×	×	×	×	X.C	X.C	Y.SB	220u	×
FR_1760DS	DC24V	03P9223B	○	○	○	×	×	×	×	×	×	×	S.C	S.C	V.F	220u	×
FR_1505/10M3	DC12V	03P9223C	×	×	×	×	×	×	×	×	×	×	X.C	X.C	Y.SB	220u	○
FR_1505/10/25M3	DC24.32V	03P9223D	○	○	○	×	×	×	×	×	×	×	X.C	X.C	Y.SB	220u	○

DRAWN Jan 26 '99 E. Kishino	FR-1525M3	TYPE	03P9223
CHECKED Jan 26 '99 K. Kamata	FR-1510M3	名称	DC電源基板
APPROVED Jan 26 '99 M. Yamamoto	FR-1505M3	回路図	回路図
SCALE MASS kg	FR-1725 FR-1710	APPLICABLE TO; (MODEL)	DC POWER BOARD
DWG NO. C3453-K04-C	1B 1 1B 1	BLOCK NO.	SCHEMATIC DIAGRAM
	03-141-6005-4		

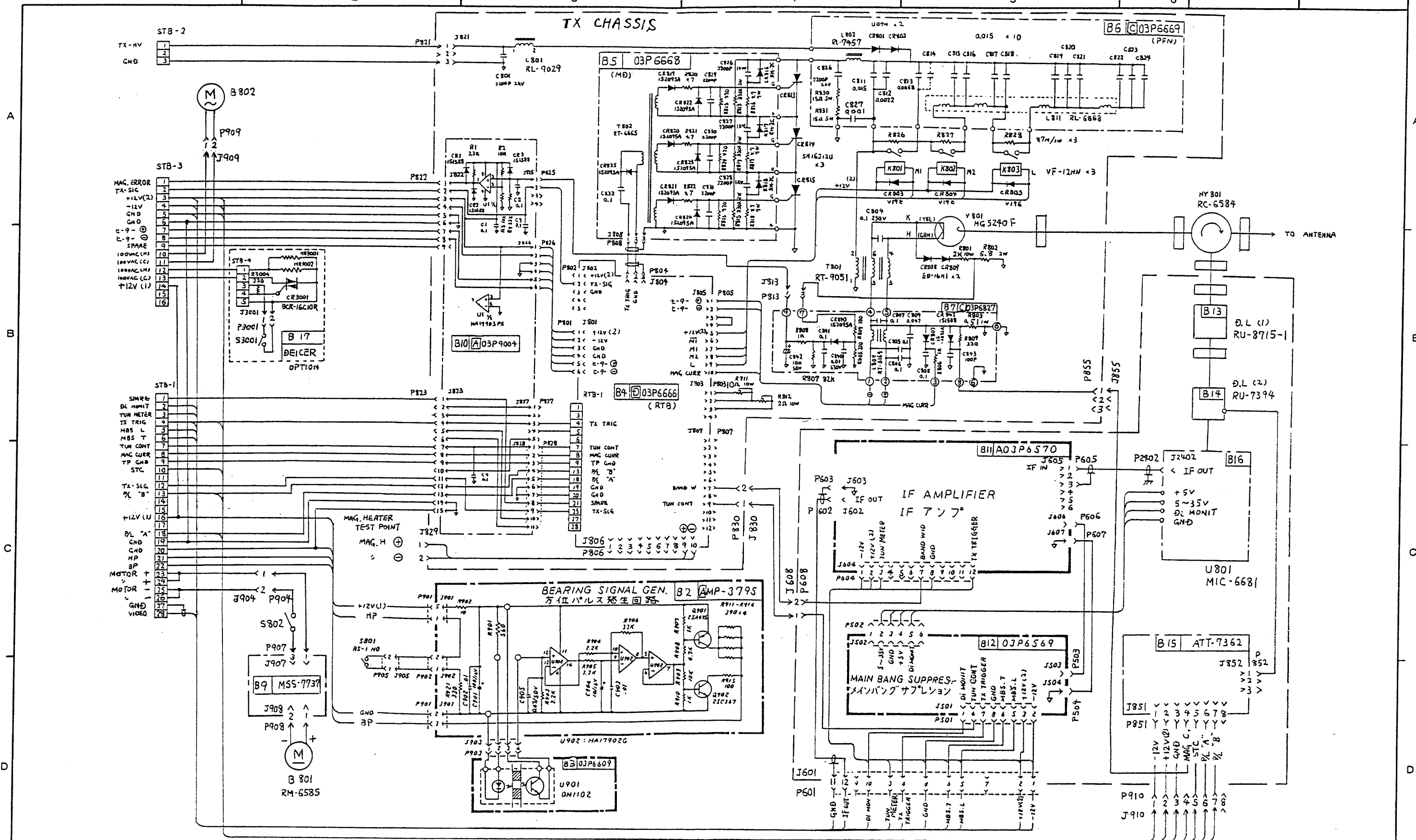

DRAWN Jun 22 '98 T. YAMASAKI	FR-1760DS FR-2165DS FR-1460DS FR-2160DS	TYPE RSB-0051
CHECKED Jun 23 '98 K. Kusunoki	APPLICABLE TO: (MODEL)	名称 空中線部総合
APPROVED Jun 23 '98 K. Kusunoki	BLOCK NO.	回路図
SCALE MASS kg	NAME SCANNER UNIT GENERAL	
DWG NO. C3357-K02- E	03-107-6003- 5	SCHEMATIC DIAGRAM

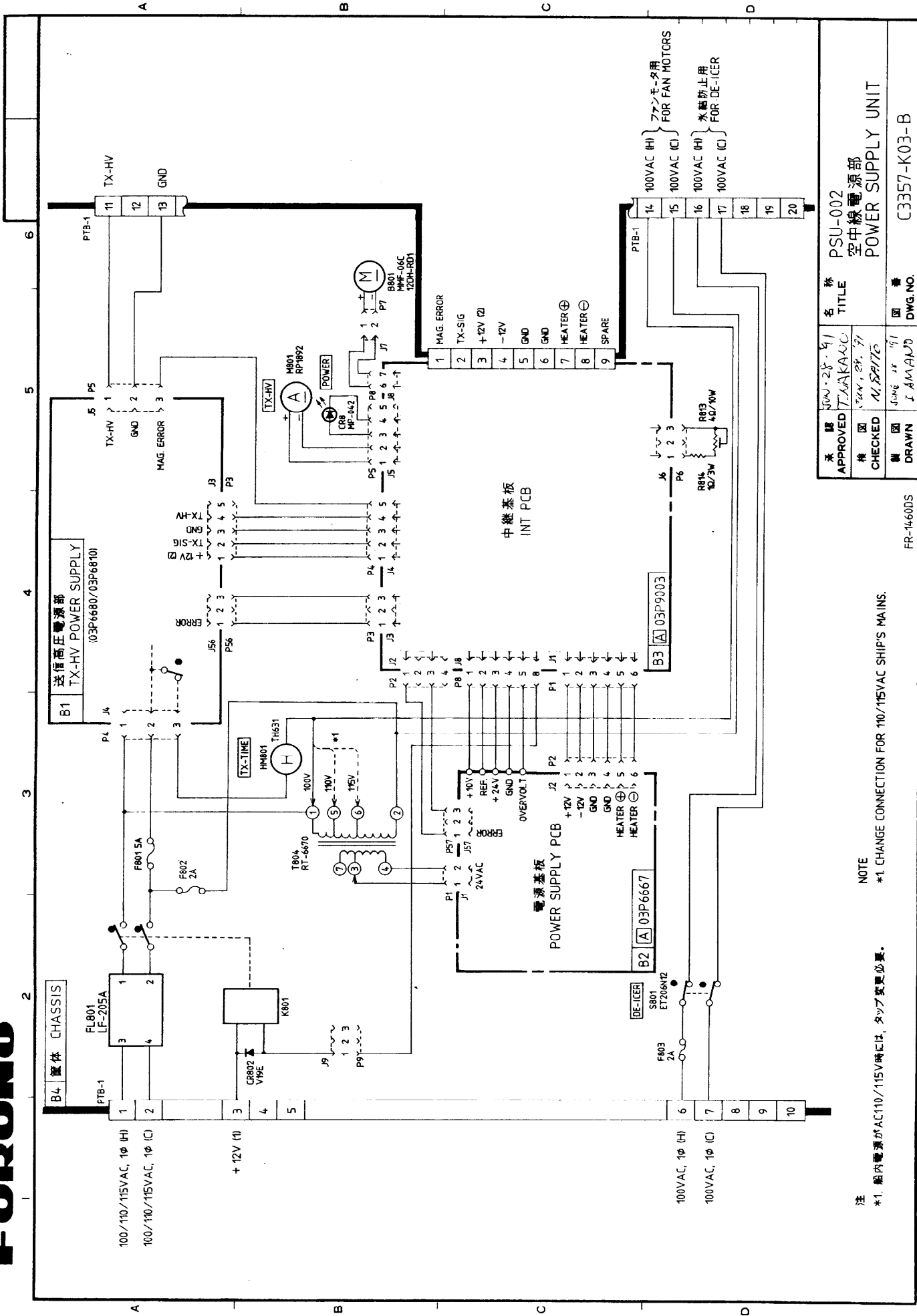

承認 APPROVED	NOV. 28. 91	名称 TITLE	PSU-002 空線電源部 POWER SUPPLY UNIT
検閲 CHECKED	TAKAKU	国番 DWG. NO.	C3357-K03-B
製図 DRAWN	SAITO		

FR-14600S

注  
\*1. 船内電源がAC110/115V時には、タップ変更必要。

NOTE  
\*1. CHANGE CONNECTION FOR 110/115VAC SHIP'S MAINS.